



KLIXON® | 7851 & 7854 Series

12.5 to 60 Amp Commercial Thermal Circuit Breaker

FEATURES

- 30VDC or 120VAC, 12.5 to 60 Amps
- Sealed assemblies, manual and automatic reset options
- Ignition protected SAE J1171
- Weatherproof SAE J553
- UL Recognized E36869

DESCRIPTION

The KLIXON® 7851 and 7854 series thermal breakers were designed to protect wiring and meet the harshest environmental requirements. The 7851 and 7854 series closed construction circuit breakers are weatherproof sealed for protection against moisture, dust, grease, fuel vapors and other harsh environments. The 7851 and 7854 series breakers are compact, lightweight and designed to interrupt short circuits or overloads, and combine trip-free protection with fast response time. Typical applications are protection of wire cable of accessory circuits, equipment and battery protection in construction and off-road equipment, marine, recreational vehicles (RV's), mining, agricultural equipment and electric (hybrid) vehicles.

ORDERING INFORMATION

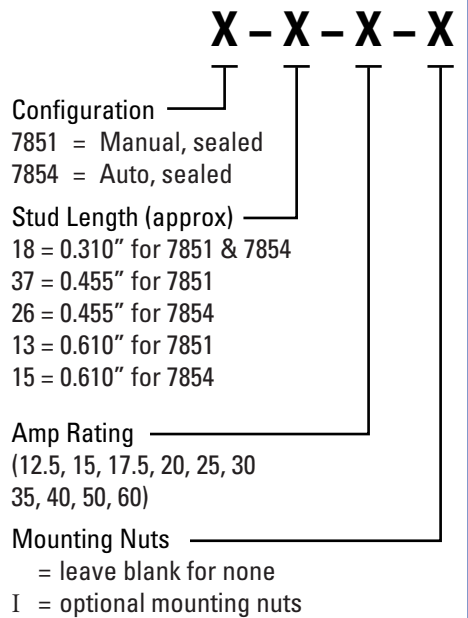

PERFORMANCE CHARACTERISTICS

Calibration : 200% rated current, 77°F (25°C)	12.5 to 60 amps : 5 to 55 seconds
Ultimate Trip At 77°F (25°C)	Must hold 100%, Must trip 135%
Endurance	Per SAE J553
Interrupt Current Capacity	Per SAE J553 and ABYC E-11
Vibration	10G MIL-STD-202 Method 204, Condition A
Salt Spray	MIL-STD-202 Method 101D
Dielectric Strength	MIL-STD-202 Method 301, 1500VAC min
Insulation Resistance	MIL-STD-202 Method 302, Condition B, 100MΩ min
Weight (with mounting nuts)	7851 : 54 grams max 7854 : 49 grams max

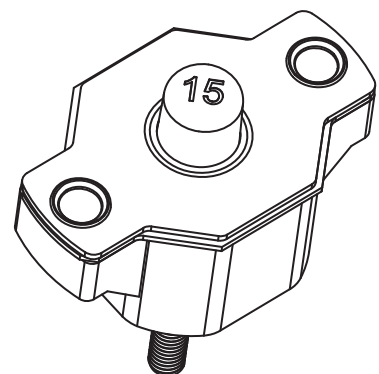

TRIP CURVE - Approximate Time, Current Characteristics At 77°F (25°C)

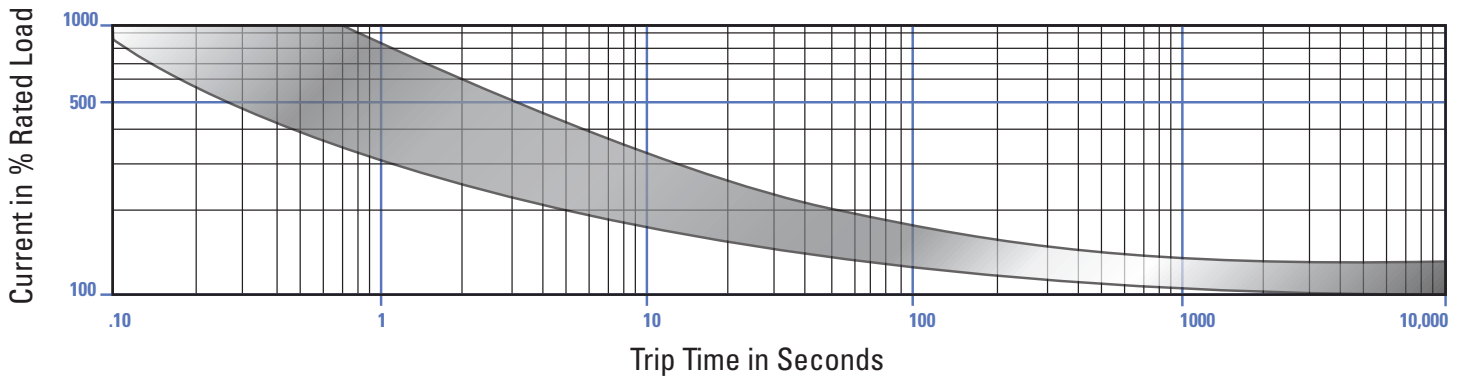

DIMENSIONS - 7851

INCHES [MM]

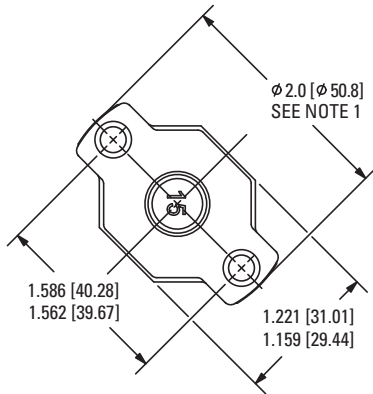

(DOES NOT INCLUDE SEALING GASKET)

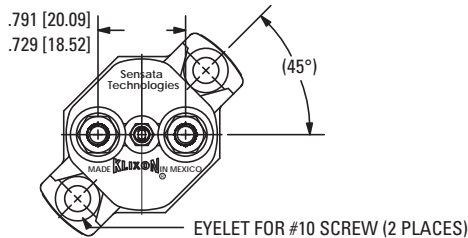
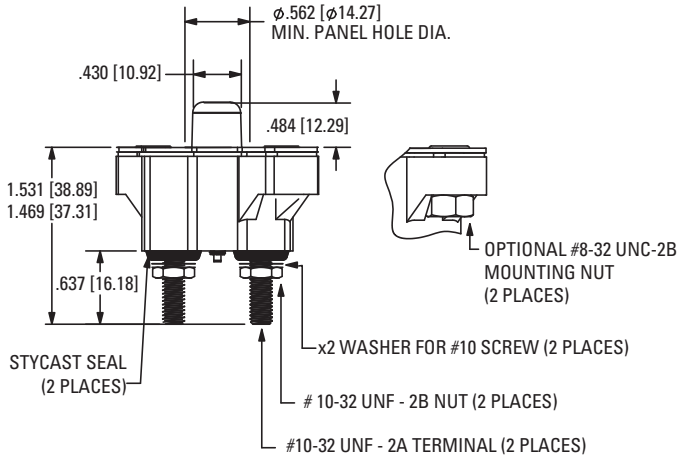

DERATING CURVE

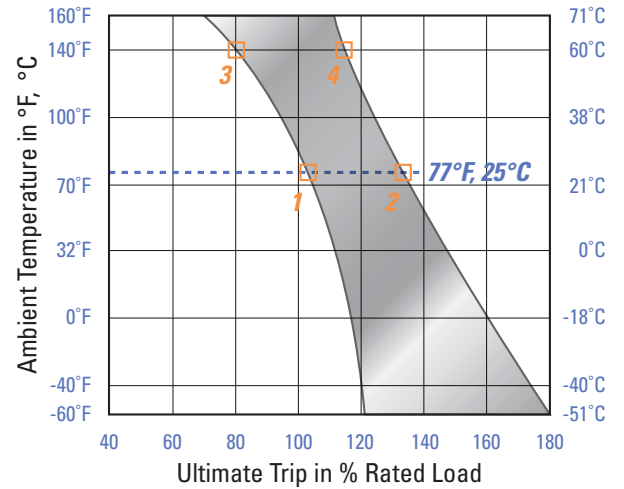

Performance characteristics are based on room temperature (77°F, 25°C). Consult Derating curve for ambient temperatures significantly higher or lower than standard room temperature.

Example: At 77°F (25°C) the device is calibrated to hold at 100% of rated current (1) and trip at 135% of rated current (2). At 140°F (60°C), the same device will hold at approximately 78% of rated current (3), and trip at approximately 115% of rated current (4).