

KLIXON[®]

Precision Products Aircraft Circuit Breakers

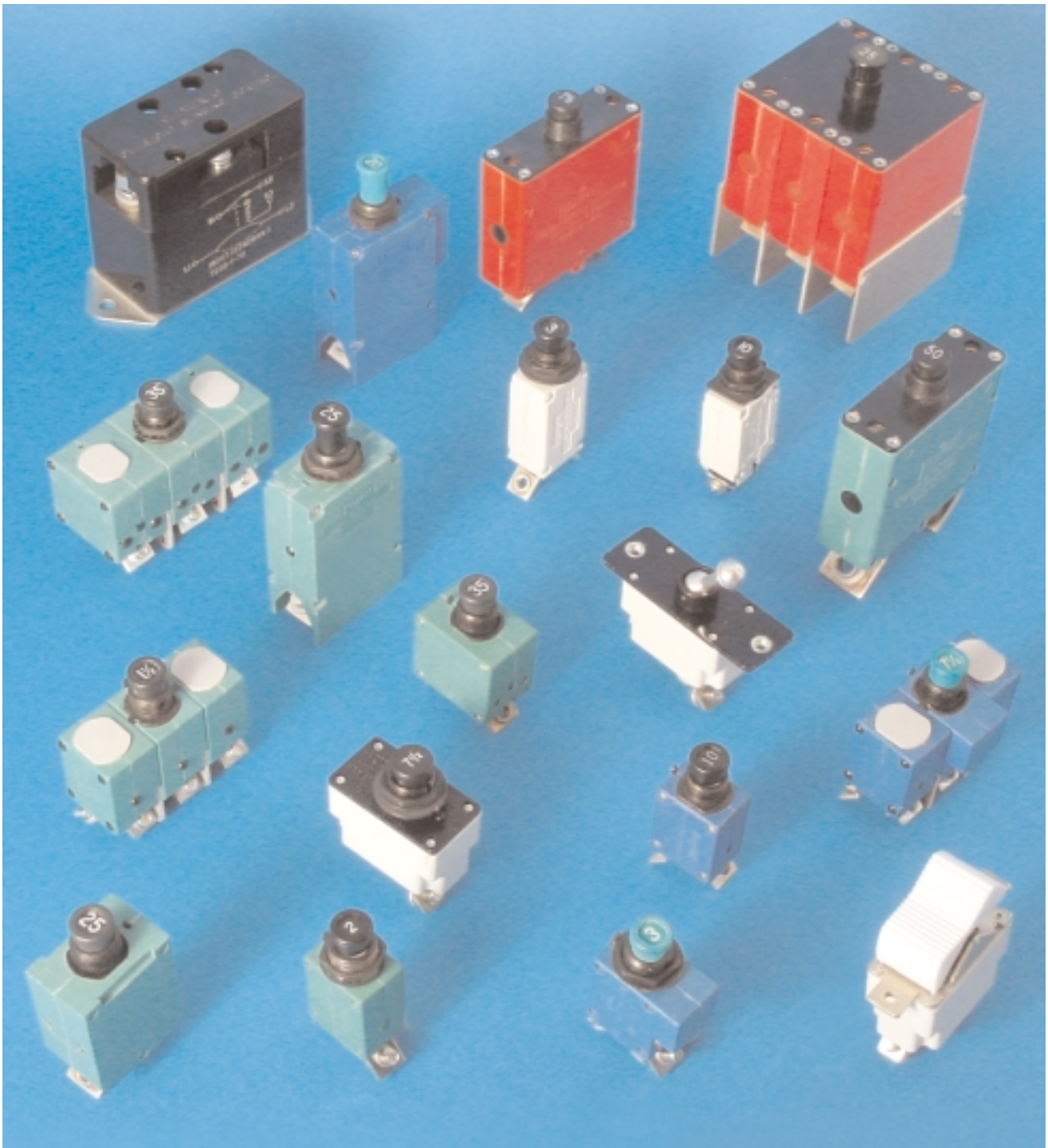

Aircraft Circuit Breakers



2TC14



2TC66



3TC14



3TC7



2TC49



5TC50



6752-12



6752-305



6752-100



7277-2



7277-1



20TC



7274-2



7274-4



7274-11 and 7274-69



7270-7



7271-8



7271-3



7270-1



6TC



9TC



3SB2



3SB4

Overview

TI is the leading supplier of circuit breakers to the global aircraft industry and has established the industry standard for quality, reliability, and performance. TI has pioneered virtually all of the aircraft circuit breakers styles used in today's aircraft. TI's complete line of circuit breakers offers a broad selection of types, features and design options.

- Single pole or three pole versions
- Ratings from ½ to 100 amps
- Trip free design
- Temperature or non-temperature compensated
- Excellent vibration and shock resistance
- Qualified to global commercial and military standards
- Optional auxiliary switch
- Thermal and magnetic sensing
- Push button, toggle or rocker switch
- Long push button
- Various terminal configurations
- MS and commercial configuration
- Manual reset
- 28VDC or 120VAC, 400 Hz

Applications

TI's broad circuit breaker product line is ideal for those rugged applications that require a high level of reliability and performance as well as excellent vibration and shock resistance including:

- Power distribution systems on commercial and military aircraft
- Ground support equipment
- Avionics
- Missile launcher systems
- Aircraft simulators
- Power distribution systems on military vehicles

Index

TI Number	Page
Guide	2, 3
2TC, 3TC	4, 5
6TC, 9TC.....	6, 7
2TC49	8, 9
5TC	10, 11
6752	12, 13
6752-100	14, 15
3TC7.....	16, 17
7274-2,-4,-11,-69	18, 19
7277	20
20TC	21
7270-1, 7271-8	22, 23
3SB2, 3SB4.....	24, 25
Arc Fault	26, 27
Cross Reference	28
Glossary	29

TI maintains a complete line of MS and customer approvals on most major aircrafts worldwide. Due to space limitations, these configurations cannot all be shown.

7276 style aircraft circuit breaker is not shown in the catalog.



Condensed Aircraft Circuit Breaker Guide

This guide gives a brief description of most circuit breakers manufactured by Texas Instruments. For more information, please consult the appropriate section of this catalog.

CIRCUIT BREAKER TYPE NUMBER	TYPE	APPROVAL	ACTUATING OR RESET MEANS	MANUAL TRIP	INDICATING	RATING IN AMPS	MAJOR DIMENSIONS IN INCHES APPROX. L x W x H	APPROX. WT. IN GRAMS	APPROX. 200% TIME SECONDS TIME TO TRIP AT TWICE RATED CURRENT
2TC 3TC	Aircraft	MS 3320 MS 14105	Button	Yes	Yes	1 - 25 15 - 35	.75 x .56 x 1.2 1.10 x .75 x 1.2	25.0 36.0	10 10
5TC	Aircraft	---	Button	Yes	Yes	20 - 50	1.65 x .77 x 1.92	57.5 (std.) 59.4 (aux.)	10
6TC 9TC	Aircraft	MS 14154 MS 14153	Button	Yes	Yes	2 - 20 1, 15 - 35	.75 x 1.78 x 1.2 1.10 x 2.35 x 1.2	65.0 110.0	10 10
2TC49	Aircraft	M5809/1	Button	Yes	Yes	2.5 - 15	1.21 x .75 x .56	25.0	10
3TC7	Aircraft	MS 25244	Button	Yes	Yes	5 - 35	1.1 x .75 x 1.49	38.9	35
6752-12 6752-100 6752-305	Aircraft	MS 24571 MS25361	Button	Yes	Yes	2.5 - 50 50 - 100 2.5 - 90	2.2 x .75 x 3.3 2.2 x .75 x 3.3 2.2 x 2.25 x 3.3	91.0 91.0 292.0	35
7274	Aircraft	MS 26574 MS 22073	Button	Yes	Yes	1/2 - 20	.750 x .562 x 2.2	28.0 32.0	10
7277	Aircraft	---	Button	Yes	Yes	1/2 - 20	.750 x .562 x 2.2	25.0	10
7270 7271	Aircraft	MS 24509 MS 24510	Toggle Button	Yes	Yes	3 - 35	1.37 x .75 x 2.25 1.37 x .75 x 2.00	39.0	50 50
20TC2	Aircraft	---	Rocker	Yes	Yes	3 - 35	2 x .750 x 2	39.0	50
3SB	Simulator	---	Button	Yes	Yes	---	.750 x .562 x 2.2	30.0	---

MIL Approved Aircraft Circuit Breakers

MS Number	TI Number	Page	MS Number	TI Number	Page	MS Number	TI Number	Page
MS 3320	2TC2	4, 5	MS 14154V	6TC63	6, 7	MS 26574	7274-2	18, 19
MS 3320L	2TC27	4, 5	MS 5809/1	2TC49	8, 9	MS 26574A	7274-4	18, 19
MS 3320V	2TC63	4, 5	MS 24571	6752-12	12, 13	MS 26574L	7274-70	18, 19
MS 14105	3TC2	4, 5	MS 24571V	6752-12	12, 13	MS 24509A	7270-1	22, 23
MS 14105L	3TC27	4, 5	MS 25361	6752-100	14, 15	MS 24509B	7270-7	22, 23
MS 14153	9TC2	6, 7	MS 25361V	6752-102	14, 15	MS 24510A	7271-8	22, 23
MS 14154	6TC2	6, 7	MS 22073	7274-11	18, 19	MS 24510B	7271-3	22, 23
MS 14154L	6TC37	6, 7	MS 22073V	7274-69	18, 19	MS 25244	3TC7	16, 17

*Note: For cross reference information, refer to page 28.

Condensed Aircraft Circuit Breaker Guide

CIRCUIT BREAKER TYPE NUMBER	FAULT INTERRUPTING CAPACITY AMPS @ VOLTS & CYCLES	REMARKS	TYPICAL APPLICATIONS
2TC 3TC	6000 @ 28 VDC 2500 @ 120 VAC, 400 Hz 6000 @ 28 VDC 2000 @ 120 VAC, 400 Hz	Subminiature, ambient compensated 1 pole auxiliary switch available	Aircraft power distribution
5TC	4000 @ 28 VDC 2000 @ 115 VAC, 400 Hz	Ambient compensated	Aircraft, avionics, and electrical systems
6TC 9TC	2000 @ 120 VAC, 400 Hz 2000 @ 120 VAC, 400 Hz	Subminiature, ambient compensated, 3 pole	Aircraft power distribution
2TC49	6000 @ 28 VDC 2500 @ 120 VAC, 400 Hz	Dual Safety 2TC	Aircraft power distribution
3TC7	6000 @ 30 VDC 3500 @ 120 VAC, 400 Hz	Lightweight, high performance, non-ambient temperature compensated	Aircraft, avionics, and electrical systems
6752-12 6752-100 6752-305	6000 @ 30 VDC 120 VAC, 400 Hz	1 Pole – 6752-12 1 Pole – 6752-100 3 Pole – 6752-305	Aircraft power distribution ground support
7274	2000 @ 28 VDC 500 @ 125 VAC, 400 Hz	Quick acting, subminiature auxiliary switch available	Aircraft power distribution, Avionics, ground support, missile systems
7277	2000 @ 28 VDC 500 @ 120 VAC, 400 Hz	Wide calibration version of 7274	Protection of wire, motors, solenoids, transformers in electronics
7270 7271	4000 @ 30 VDC 3500 @ 120 VAC, 400 Hz	Toggle or push button	Aircraft power distribution
20TC2	2000 @ 30 VDC 1000 @ 120 VAC, 400 Hz	Rocker switch type	Combination circuit switching & protection light aircraft, electronics, vehicles
3SB	--	Push button	Commercial and military simulators

*Note: For FAA/PMA approved devices, go to www.klixon.com



Single Phase TC Series Circuit Breakers

Miniature Ambient Compensated

Features

- **Miniature size**
- **Light weight**
- **Trip free**
- **Mil-qualification**
- **Current rating 1-35 amperes**
- **Coordinated ratings**
- **High vibration resistance**
- **High interrupt capacity**

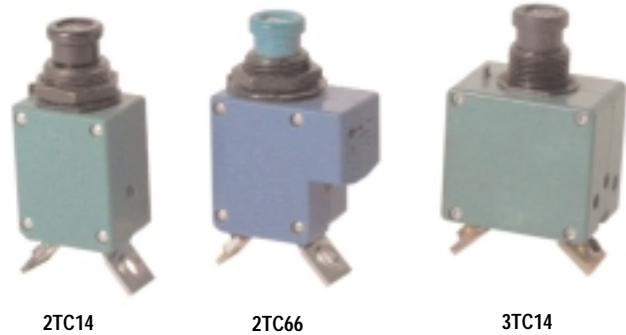

Overview

Klixon® single-phase TC devices are the smallest, lightest aircraft circuit breakers available today. They represent “state-of-the-art” protection for today’s aerospace power systems. Their light weight and small size make them especially well suited for aircraft, avionics and electronic systems.

The Klixon trademark has set the standard for aerospace circuit breakers. Despite the small size, the TC series offers the endurance and reliability required by exacting military specifications, and are available in standard current ratings from 1 – 35 amperes.

Coordination

The 2, 3, 6 and 9TC breaker ratings are coordinated so any rating will trip before another circuit breaker, twice its rating, in the event of a fault of up to 6000 amps let-thru current. This results in improved overall equipment performance, since only the smallest faulted circuit is interrupted, while larger circuits remain operational (see pages 6 and 7 for 6/9TC details).

Ambient Temperature Compensation

Ambient compensated circuit breakers permit system designers to specify smaller gauge wire where the circuit breaker and wiring are exposed to different ambient temperatures. They are especially suited for applications where the ambient temperature exceeds the 160°F maximum of non-ambient compensated thermal circuit breakers. The TC series may be applied where operating temperatures are as high as 250°F (121°C), with no derating of the circuit breaker. This eliminates the need for cooling air and allows substantial weight, space and cost savings.

Options*

- Longer push buttons
- High vibration
- Random vibration
- Metric mounting thread
- Metric terminal thread
- Dust boot†
- Auxiliary switch - male and female contacts available
- Terminal barriers
- Plug-in terminals

Trip Free

The complete line of TC series circuit breakers is trip free. The circuit breaker cannot be maintained closed during an overload even with the actuator button held closed.

High Short Circuit Capacity

For its miniature size, the 2/3TC series offers unusually high current interrupting capacity. Overloads up to 6000 amps at 28 VDC or 2000-3500 amps at 120 VAC, 400 Hz can be safely interrupted without affecting calibration or operating performance in the standard 2/3TC series.

Qualifications

MS3320 - 2TC2
MS3320L - 2TC27
MS3320V - 2TC63
MS14105 - 3TC2
MS14105L - 3TC27
European standards
SAE standards
All U.S. aircraft OEM's
Most European aircraft OEM's

* Contact factory for details
† Part Number 14500-1 Fits 15/32 Bushing
Part Number 14500-5 Fits 7/16 Bushing

2TC14

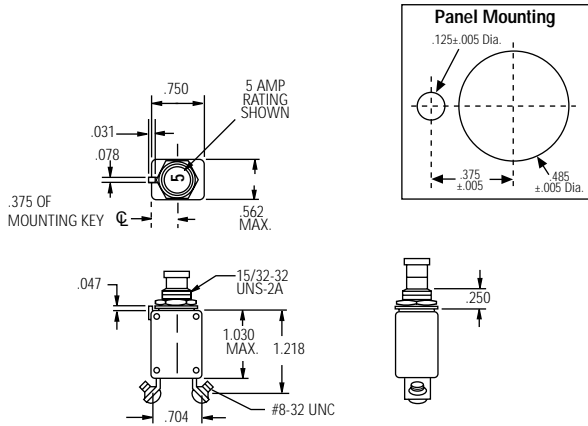

3TC14

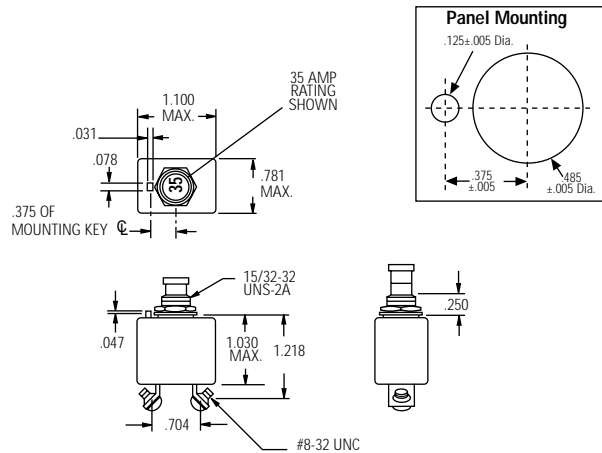

Calibration: 1-25 amps

TEMP °C	MIN ULT TRIP	MAX ULT TRIP	TRIP TIME - SECONDS		
			200%	500%	1000%
+25	115%	138%	4-16	.4-1.6	.10-.40
-54	115%	165%	7-35	.6-3.0	.15-.70
+121	85%	145%	2-13	.25-1.0	.06-.25

Calibration: 15-35 amps

TEMP °C	MIN ULT TRIP	MAX ULT TRIP	TRIP TIME - SECONDS		
			200%	500%	1000%
+25	115%	138%	4-20	.40-1.7	.10-.40
-54	115%	165%	6-35	.55-3.0	.15-.70
+121	85%	145%	2-15	.25-1.0	.06-.25

Vibration*..... 10 G's minimum, 50 - 500 Hz
 Mechanical Shock..... 50 G's
 Acceleration..... 10 G's
 Weight..... 2TC14 - 24 gm max.
 3TC14 - 36 gm max.

Interrupt Current

1-20 amps: 6000 amps at 28 VDC
 25 amps: 1625 amps at 28 VDC
 1-15 amps: 2500 amps at 120 VAC, 400 Hz
 20 amps: 2000 amps at 120 VAC, 400 Hz
 25 amps: 1800 amps at 120 VAC, 400 Hz

Endurance

2500 cycles 120 VAC, 400 Hz Inductive
 5000 cycles 120 VAC, 400 Hz Resistive
 2500 cycles 30 VDC Inductive
 5000 cycles 30 VDC Resistive
 10,000 cycles Mechanical, no load

* Other vibration levels available. Contact factory for details.

TI Number	Voltage Drop (max.)**
2TC14-1	1.10
2TC14-2	0.70
2TC14-2½	0.50
2TC14-3	0.40
2TC14-4	0.45
2TC14-5	0.35
2TC14-7½	0.30
2TC14-10	0.28
2TC14-15	0.25
2TC14-20	0.25
2TC14-25	0.20

TI Number	Voltage Drop (max.)**
3TC14-15	0.25
3TC14-20	0.25
3TC14-25	0.25
3TC14-30	0.25
3TC14-35	0.25

**Max. voltage drop at nominal rated current.

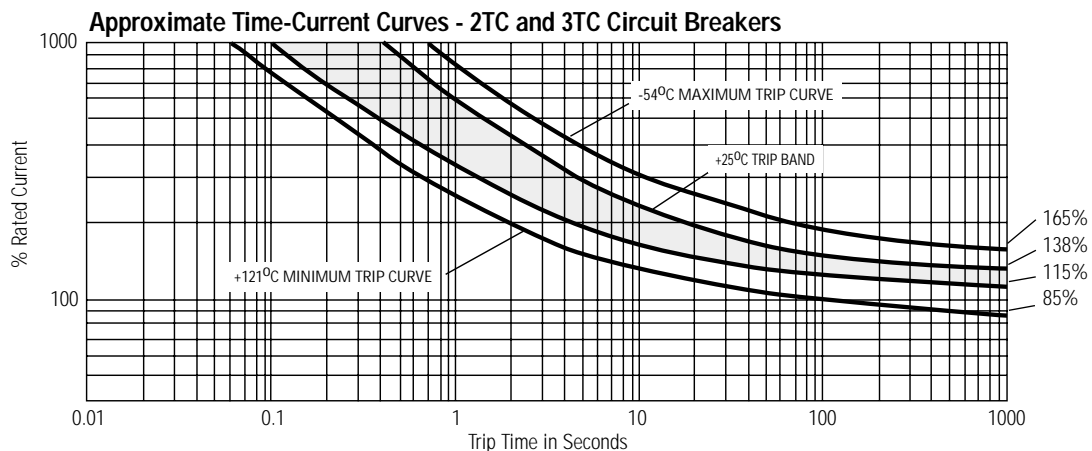



Three Phase TC Series Circuit Breakers

Miniature Ambient Compensated

Features

- **One phase trips all**
- **Protective shields between each phase's terminals**
- **Pads increase mounting stability**
- **Also includes identical features as 2TC and 3TC**

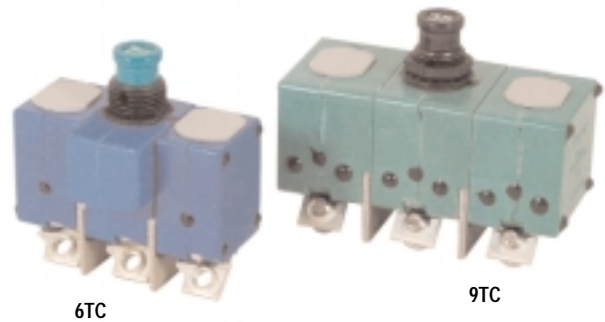

Overview

The 6TC and 9TC circuit breakers provide ambient compensated circuit protection in a lightweight, subminiature package size. The three phase design integrates each individual phase to provide overcurrent protection in the event of simultaneous or unbalanced overloads, including short circuit conditions.

Coordination

The 6TC and 9TC are compatible with their single phase 2TC and 3TC cousins. The 6TC and 9TC are available in ratings from 1-35 amps, with military and various commercial approvals on most styles.

Ambient Temperature Compensation

The 6TC and 9TC are ambient compensated circuit breakers. This allows usage of smaller gauge wire.

The 6TC and 9TC can operate over a temperature range of -54°C to 121°C , however, care should be taken to understand the specification limits at elevated ambient temperatures.

Options*

- Longer push buttons
- High vibration
- Metric mounting thread
- Metric terminal thread
- Dust boot†
- Auxiliary switch device available††

* Contact factory for details

† Part Number 14500-1 fits 15/32 bushing
Part Number 14500-5 fits 7/16 bushing

†† 6TC Device

Trip Free

The complete line of TC series circuit breakers is trip free. The circuit breaker cannot be maintained closed during an overload, even with the actuator button held closed.

High Short Circuit Capacity

For its miniature size, the 6/9TC series offers unusually high current interrupting capacity. Overloads up to 2000 amps at 120 VAC, 400 Hz can be safely interrupted without affecting calibration or operating performance in the standard 6/9TC series.

Qualifications

MS14154	6TC2
MS14154L	6TC37
MS14154V	6TC63
MS14153	9TC2

European standards

SAE standards

All U.S. aircraft OEM's

Most European aircraft OEM's

Characteristics

6/9TC

6TC14

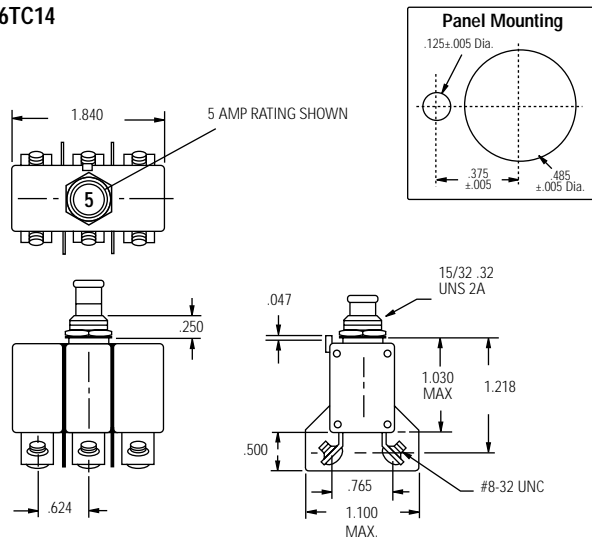

9TC14

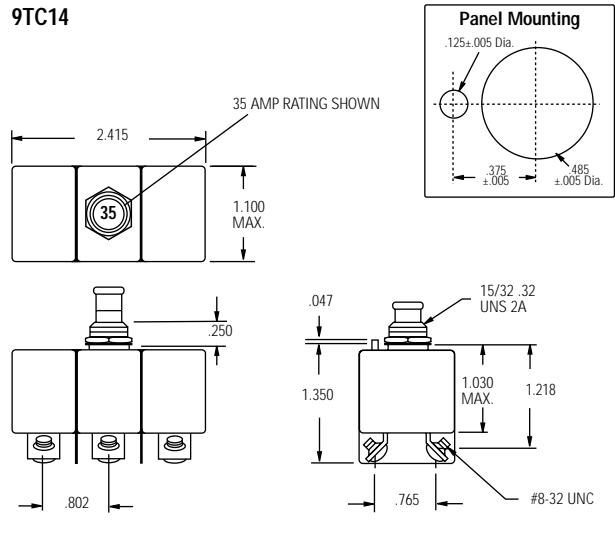

Calibration: 2-20 amps

TEMP °C	MIN ULT TRIP	MAX ULT TRIP	TRIP TIME - SECONDS		
			200%	500%	1000%
+25	110%	145%	4-20	.40-2.0	.10-.53
-54	110%	165%	6-40	.55-3.5	.15-.80
+90	100%	145%	3-20	.33-1.7	.08-.40
+121	90%	145%	3-20	.33-1.7	.08-40

† Single phase max. ult. trip values apply with other two phases carrying 100% of rated current.

Vibration* 10 G's minimum, 50-500 Hz
 Mechanical Shock 50 G's
 Acceleration 10 G's
 Weight 6TC14 - 65 gm max.
 9TC14 - 110 gm max.

Interrupt Current

2-20 amps: 2000 amps at 120 VAC, 400 Hz
 1, 15-35 amps: 2000 amps at 120 VAC, 400 Hz

Endurance

2500 cycles 120 VAC, 400 Hz Inductive
 5000 cycles 120 VAC, 400 Hz Resistive
 5000 cycles Mechanical, no load

* Other vibration levels available. Contact factory for details.

Calibration: 1, 15-35 amps

TEMP °C	MIN ULT TRIP	MAX ULT TRIP	TRIP TIME - SECONDS		
			200%	500%	1000%
+25	110%	145%	4-20	.40-2.0	.10-.53
-54	110%	165%	6-40	.55-3.5	.15-.80
+90	100%	145%	3-20	.33-1.7	.08-.40
+121	90%	145%	3-20	.33-1.7	.08-40

† Single phase max. ult. trip values apply with other two phases carrying 100% of rated current.

TI Number	Voltage Drop (max.)
6TC14-2	0.70
6TC14-2½	0.50
6TC14-3	0.40
6TC14-4	0.37
6TC14-5	0.35
6TC14-7½	.192
6TC14-10	.176
6TC14-15	.176
6TC14-20	.176

TI Number	Voltage Drop (max.)**
9TC14-1	1.10
9TC14-15	0.25
9TC14-20	0.25
9TC14-25	0.25
9TC14-30	0.25
9TC14-35	0.25

** Max voltage drop at nominal rated current.
 (25 amp 6TC pending qualification.)

Approximate Time-Current Curves - 6TC and 9TC Circuit Breakers

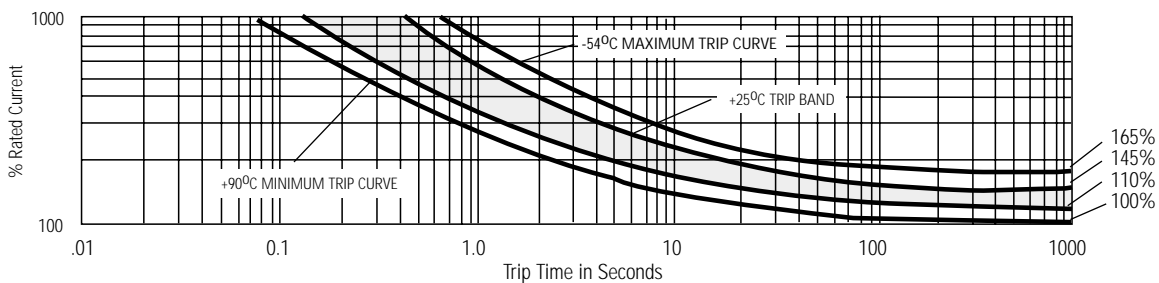



2TC49 Series

"Dual Safety™" Circuit Breakers

Features

- **Extension of 2TC series**
- **Redundant protection in hard fault catastrophic conditions**
- **Separable link feature**
- **Case color distinguishes 2TC49 from 2TC series**
- **Uses less space and weighs less than other circuit breaker packages**
- **Rating 2½ - 15 amps**



2TC49
"Dual Safety" Circuit Breaker

Overview

The 2TC49 "Dual Safety™" circuit breaker represents a refinement in electrical control and circuit protection. The 2TC dual safety circuit breaker incorporates a fusible element in a standard 2TC (MS 3320) package size to provide redundant protection in hard fault conditions.

"Hard Fault" Tripping

The 2TC dual safety circuit breaker operates identically to a standard circuit breaker under all normal conditions, including

short circuit. In the event of circumstances which disable the internal circuit breaker mechanisms, such that the device is able to carry current but unable to clear an overload via its normal means, the dual safety element acts as a built in fuse to provide redundant circuit protection.

The key part in the dual safety design is a two part current carrying element joined by a special alloy. The geometry and material of the element determine its heating properties. The

elements heating properties are slower than the bimetal sensor but faster than the smoke curve of the wire the rating is designed to protect. In the case where the standard mechanism is disabled or cannot operate normally, the separable element "fuses" open, interrupting the current.

The benefits of the dual safety design result in calibrated overcurrent protection (based on fuse times) and specified post fuse dielectric properties for system and human protection.

Characteristics

"Dual Safety™" 2TC49

2TC49

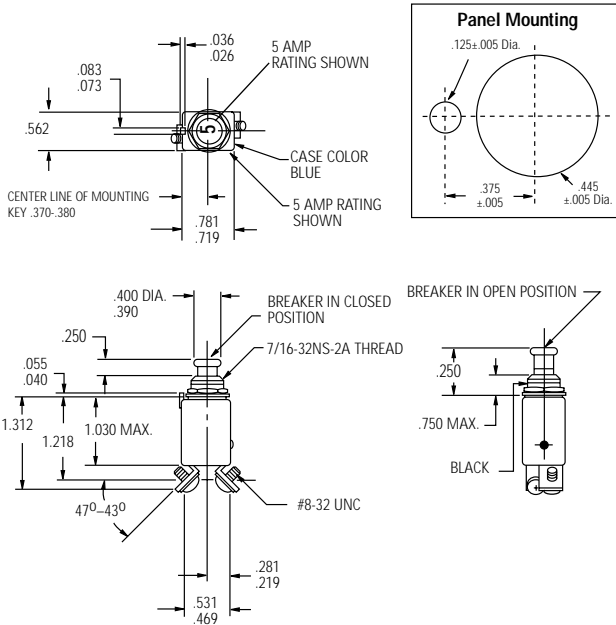

Link Separation Characteristics

Maximum circuit breaker link separation times for locked contact condition as a function of overload

Amp Rating	% Overload Rated Current						
	400%	500%	600%	700%	800%	900%	1000%
2½	-	-	34.0	20.0	13.0	9.0	6.0
3	-	-	34.0	20.0	13.0	9.0	6.0
5	-	95.0	36.0	18.0	10.0	6.0	3.5
7½	69.0	28.0	14.0	8.0	4.0	3.5	2.0
10	60.0	35.0	20.0	12.0	7.0	4.0	2.5

Time (seconds)

Calibration: 2½-15 amps

Temp °C	Min ULT Trip	Max ULT Trip	Trip Time - Seconds		
			200%	500%	1000%
+25	115%	138%	5-20	.5-2.0	.12-.53
-54	115%	165%	7-40	.6-3.0	.16-.8
+121	90%	138%	3-13	.33-1.1	.07-.3

Vibration* 10 G's minimum, 50-50 Hz
 Mechanical Shock 50 G's
 Acceleration 10 G's
 Weight 2TC49 - 25 gm max.

Post-short circuit dielectric 1125 VAC Min (1mA)
 Post-link separation dielectric 900 VAC (1mA)

Interrupt Current

2½ - 15 amps: 6000 amps at 28 VDC
 2½ amps: 2800 amps at 120 VAC, 400 Hz
 3 - 15 amps: 2500 amps at 120 VAC, 400 Hz

Endurance

2500 cycles 120 VAC, 400 Hz Inductive
 5000 cycles 120 VAC, 400 Hz Resistive
 2500 cycles 30 VDC, Inductive
 5000 cycles 30 VDC, Resistive
 10,000 cycles Mechanical, no load

* Other vibration levels available. Contact factory for details.

TI Number	Voltage Drop (max.)**
2TC49-2½	0.70
2TC49-3	0.55
2TC49-5	0.35
2TC49-7½	0.30
2TC49-10	0.28

** Max. voltage drop at nominal rated current

Approximate Time-Current Curves - 2TC49 Circuit Breakers

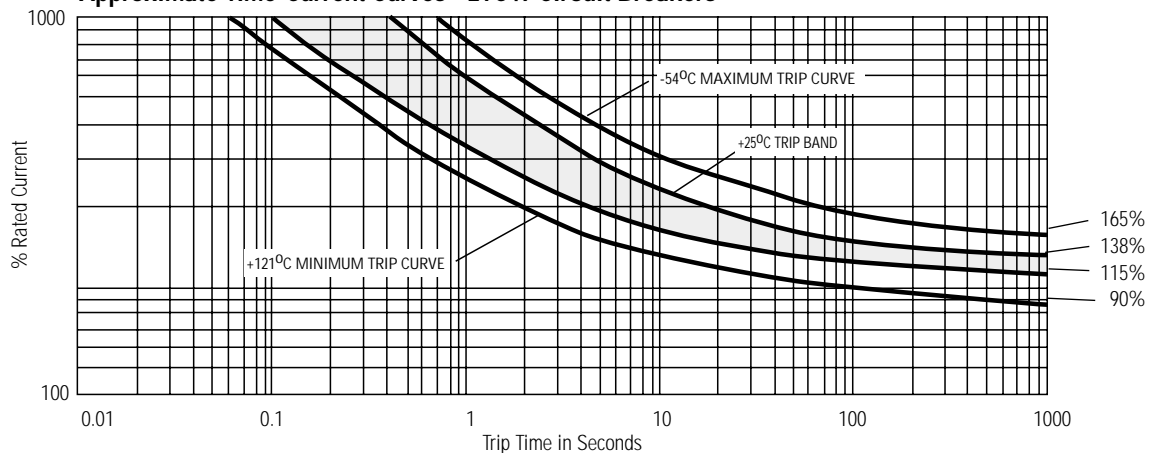



5TC Series

Single Phase, Ambient Compensated

Features

- Trip free
- Current ratings (20 - 50amps)
- Coordinated ratings
- High vibration resistance
- High interrupting capacity



Overview

Klixon® single-phase TC devices represent “state-of-the-art” protection for today’s aerospace power systems.

The Klixon trademark has set the standard for aerospace circuit breakers. The TC series offers the endurance and reliability required by exacting military specifications and is available in standard current ratings from 20 – 50 amperes.

Coordination

The single phase 5TC rating is coordinated so it will trip before another circuit breaker, twice its rating, in the event of a fault of

up to 600 amps let through current. This results in improved overall equipment performance, since only the smallest faulted circuit is interrupted, while larger circuits remain operational.

Ambient Temperature Compensation

The 5TC serves as an ambient compensated circuit breaker. It permits system designers to specify smaller gauge wire where the circuit breaker and wiring are exposed to different ambient temperatures. They are especially suited for application where ambient temperature exceeds the 160°F (71°C) maximum of non-

ambient compensated thermal circuit breakers. The 5TC series may be applied where operating temperatures are as high as 250°F (121°C), with no derating of the circuit breaker. This eliminates the need for cooling air and allows substantial weight, space and cost savings.

Options

- Longer pushbuttons
- Standard or auxiliary switch configuration
- Terminal barriers

Qualifications

ASNE0732-0055TC65
 NSA9313215TC50

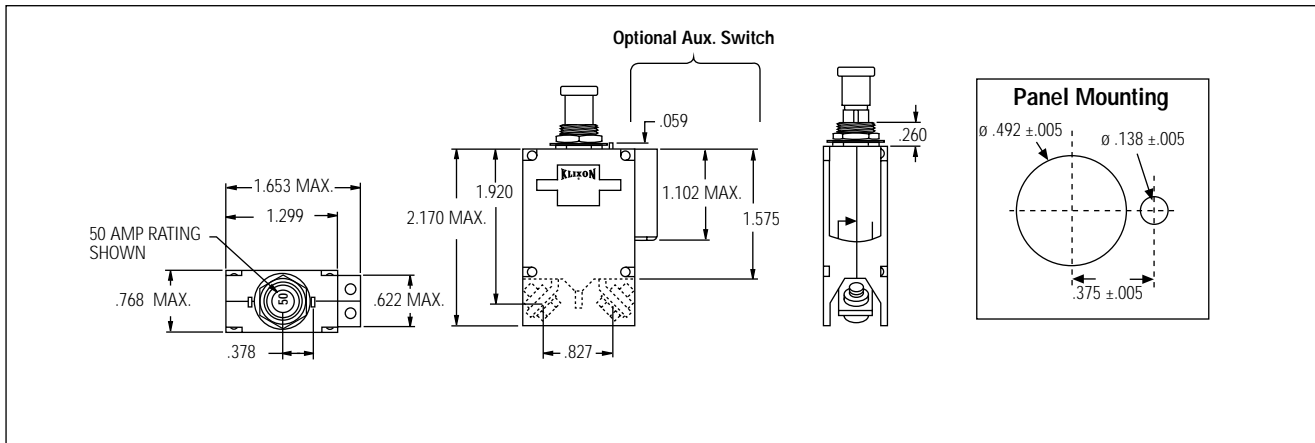

Calibration: 20-50 Amps

Temp °C	Min. ULT. Trip	Max. ULT. Trip	Trip Time - Seconds		
			200%	500%	1000%
+23	110%	145%	2-18	.15 - 2.5	.045 - .6
-54	110%	165%	70 sec. max.	.15 - 2.5	.045 - .6
+70	105%	145%	1.5 sec. min.	.15 - 2.5	.045 - .6
+125	90%	145%	1.5 sec. min.	.15 - 2.5	.045 - .6

The above calibration chart is representative of a standard commercial device. TI offers specific variants with similar performance dependant on military or customer specifications. Temperatures are $\pm 5^{\circ}\text{C}$.

Performance

Vibration	10 G's minimum, 80-500 Hz
Mechanical Shock	50 G's
Acceleration	10 G's
Weight	
Standard Device	53 grams (w/o hw), 58 grams (w/hw)
Auxiliary Device	55 grams (w/o hw), 59 grams (w/hw)

Interrupting Capacity

20-50 amps.....4000 amps at 28 VDC
 20-50 amps..... 2000 amps at 115 VAC,400 Hz

Endurance

2500 cycles.....115 VAC, 400 Hz,Inductive
 2500 cycles.....28 VDC, Inductive
 2500 cycles.....28 VDC, Resistive
 5000 cycles.....Mechanical, no load

Basic Type – Amps (20 – 50)

5TC50-XX: Std. Version

5TC65-XX: Auxiliary

XX – denotes Amp rating

Amp Rating	Voltage Drop (max)*
20	0.150
25	0.150
35	0.150
50	0.120

* Max. voltage drop at nominal rated current

Approximate Time-Current Curves - 5TC Circuit Breakers

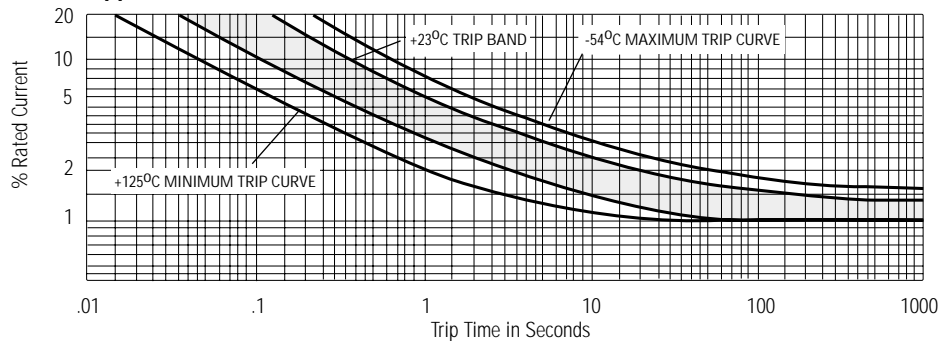



6752 Series Circuit Breakers

Ambient Compensated Single & Three Phase High Short Circuit Capacity

Features

- Useable on large electrical systems – 6000 amperes interrupting capacity
- Circuit protection unaffected by temperature fluctuation – ambient compensated from -65°F to +250°F
- Only faulted line circuits opened – coordination of ratings ensures that branch circuit breakers trip first under fault conditions
- Long trouble-free operation – 20,000 operating cycles
- Military approved
- High amp devices available (65A & 90A)

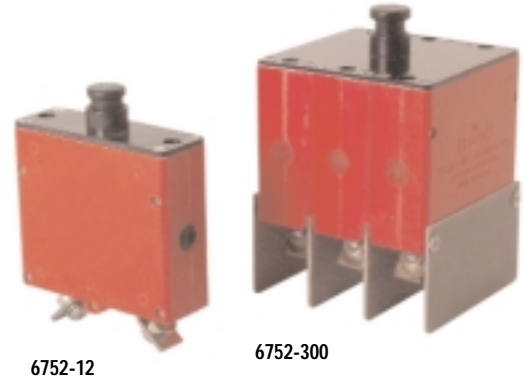

Overview

The Klixon 6752-12 and -300 series thermal-magnetic circuit breakers are ambient compensated and trip-free. They are designed and manufactured to meet the more stringent military standards of today's jet aircraft, specifically MIL-C-22715 (USAF).

The higher short circuit capacity, vibration resistance and longer cycling life of the 6752-12 and -300 series exceed previous military standards. In addition, the 6752-12 and -300 series provide ambient compensation, fault coordination of all ratings, and an option for auxiliary circuits.

High Short Circuit Capacity

A deionizing grid and magnetic assist enable the 6752-12 and -300 series to successfully interrupt four fault currents of 6000 amperes – two at sea level and two at 60,000 feet – on either a 120 VAC, 400 Hz system or a 30 VDC system.

Ambient Temperature Compensation

Substantially unaffected by ambient temperature, the 6752-12 and -300 series circuit breakers maintain their performance capabilities by means of a thermal compensator in the temperature range of -54°C to +121°C.

Coordination

The 6752-12 and -300 series breaker ratings are coordinated so any rating will trip before another rating, twice its capacity, in the event of a fault. This results in improved over-all equipment performance, since only the smallest faulted circuit is removed while larger circuits remain in operation.

Auxiliary Circuit

The 6752-12 and -300 series are available with auxiliary switch. For part numbers and characteristics, please consult the factory.

MIL Qualification

TI Number	MS Number	MS Number
6752-12-2½	MS 24571-2	MS 24571-2V
6752-12-5	MS 24571-5	MS 24571-5V
6752-12-7½	MS 24571-7	MS 24571-7V
6752-12-10	MS 24571-10	MS 24571-10V
6752-12-15	MS 24571-15	MS 24571-15V
6752-12-20	MS 24571-20	MS 24571-20V
6752-12-25	MS 24571-25	MS 24571-25V
6752-12-35	MS 24571-35	MS 24571-35V
6752-12-50	MS 24571-50	MS 24571-50V

When ordering MS 24571-XX(V) style breaker by TI part number, designator must include S.R. 12507-356

Example: 6752-12-2½ is S.R. 12507-356

Characteristics

6752

6752-12

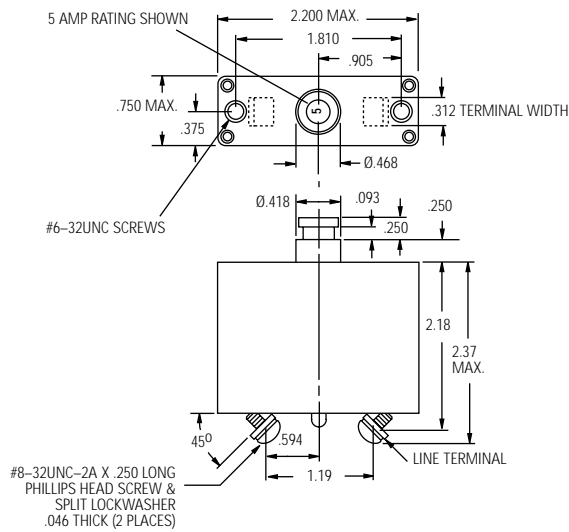

6752-305

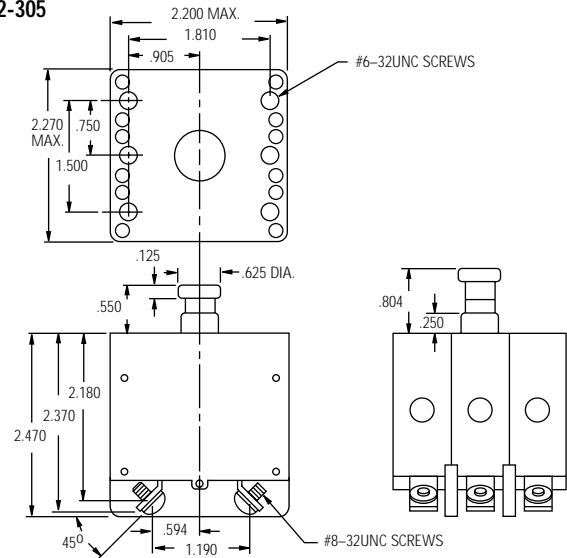

6752-12 Calibration: 2½ - 50 amps

TI Part Number	200%	400%	1000%
6752-12-2½	12-32	2.3-6.5	.32-1.1
6752-12-5	14-36	2.5-6.5	.45-1.1
6752-12-7½	16-40	2.5-7.0	.34-1.1
6752-12-10	18-42	2.7-7.75	.45-1.2
6752-12-15	20-45	2.7-8.0	.36-1.2
6752-12-20	20-48	2.7-8.0	.36-1.2
6752-12-25	20-50	2.7-8.0	.36-1.2
6752-12-35	20-53	2.7-9.5	.36-1.2
6752-12-50	20-55	2.7-8.0	.36-1.4

6752-305 Calibration: 2½ - 50 amps

TEMP °C	MIN ULT TRIP	MAX ULT TRIP	TRIP TIME - SECONDS		
			200%	400%	1000%
+25	110%	138%	12-65	2.3-10	.33-1.4
-54	110%	160%	15-65	2.3-10	.33-1.4
+93	105%	138%	12-65	2.3-10	.33-1.4
+121	100%	138%	12-65	2.3-10	.33-1.4

† Single phase max. ult. trip values apply with other two phases carrying 100% of rated current.

TI Part Number		Voltage Drop Max**
Single Phase	Three Phase	
6752-12-2½	6752-305-2½	0.60
6752-12-5	6752-305-5	0.40
6752-12-7½	6752-305-7½	0.30
6752-12-10	6752-305-10	0.25
6752-12-15	6752-305-15	0.25
6752-12-20	6752-305-20	0.25
6752-12-25	6752-305-25	0.25
6752-12-35	6752-305-35	0.25
6752-12-50	6752-305-50	0.25

** Max voltage drop at nominal rated current.

Performance Characteristics

Vibration* 10 G's minimum, 50-2000 Hz
 Mechanical Shock 25 G's
 Acceleration 10 G's
 Weight 6752-12 - 91 gm max.
 6752-305 - 292 gm max.

Interrupt Current

2½ - 50 amps: 6000 amps at 30 VDC (6752-12 only)
 2½ - 50 amps: 6000 amps at 120 VAC, 400 Hz
 2½ - 50 amps: 4200 amps at 205 VAC, 400 Hz

Endurance

5000 cycles 120 VAC, 400 Hz Inductive
 5000 cycles 120 VAC, 400 Hz Resistive
 10,000 cycles Mechanical, no load
 20,000 cycles Total

* Other vibration levels available. Contact factory for details.

Approximate Time-Current Curves 6752 Circuit Breakers

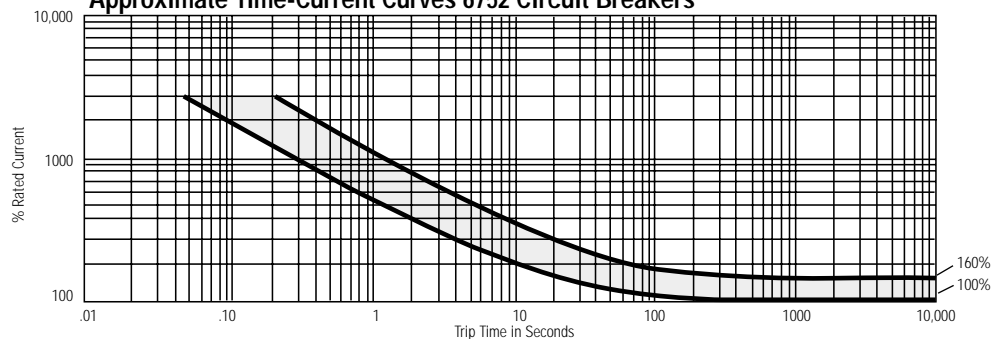



6752-100 Series Circuit Breakers

Ambient Compensated Single & Three Phase High, Short Circuit Capacity

Features

- **Current ratings from 50-100 amps**
- **Proven reliability and performance of the 6752 series circuit breaker**
- **Usable on large electrical systems – 6000 amperes interrupting capacity**
- **Circuit protection unaffected by temperature fluctuations – ambient compensated from -40°F to +160°F**
- **Military approved (including high sine vibration capability) to MS 25361 and MS 25361 (V)**



6752-100

Overview

The Klixon® 6752-100 series thermal-magnetic circuit breakers are ambient compensated and trip-free. These circuit breakers are designed and manufactured to meet stringent military standards with the reliability of the original 6752 design. The 6752-100 is similar to the 6752-12 in size, and includes current ratings ranging from 50-100 amps.

The higher short circuit capacity, vibration resistance and longer cycling life of the 6752-12 and -300 series exceed previous military standards. In addition, the 6752-12 and -300 series provide ambient compensation, fault coordination of all ratings, and an option for auxiliary circuits.

High Short Circuit Capacity

A deionizing grid and magnetic assist enable the 6752-100 series to successfully interrupt four fault 6000 amp currents, two at sea level and two at 60,000 feet, on either a 120 VAC , 400 Hz system or a 30 VDC system.

Ambient Temperature Compensation

The 6752-100 series circuit breakers maintains its performance capabilities by means of a thermal compensator in the temperature range of -40°C to +70°C.

MIL Qualification

TI Number	MS Number	TI Number	MS Number
6752-100-50	MS 25361-50	6752-102-50	MS25361-50V
6752-100-60	MS 25361-60	6752-102-60	MS25361-60V
6752-100-70	MS 25361-70	6752-102-70	MS25361-70V
6752-100-75	MS 25361-75	6752-102-75	MS25361-75V
6752-100-80	MS 25361-80	6752-102-80	MS25361-80V
6752-100-90	MS 25361-90	6752-102-90	MS25361-90V
6752-100-100	MS 25361-100	6752-102-100	MS25361-100V

Envelope Dimensions

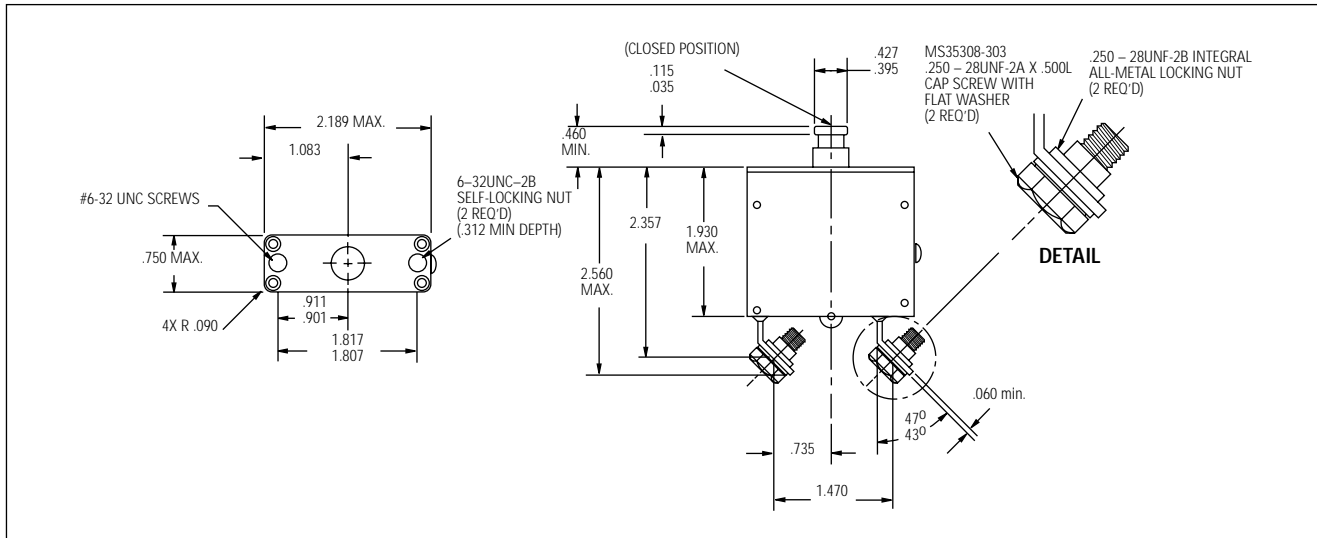

Performance Characteristics

Vibration* 10 G's minimum, 50-2000 Hz
 Mechanical Shock 30 G's
 Acceleration 10 G's
 Weight 0.25 lbs (114 gm) max.

6752-100 Calibration

Temp °C	Min ULT Trip	Max ULT Trip	Trip Time - Seconds		
			200%	400%	1000%
+25	105%	138%	15-65	2-10	1.4
-40	125%	165%	15-65	2-10	1.4
+70	70%	125%	15-65	2-10	1.4

Interrupt Current

120 VAC, 400 Hz: 3500 amps
 28 VDC: 6000 amps

Endurance

5000 cycles 120 VAC, 400 Hz Resistive
 5000 cycles 120 VAC, 400 Hz Inductive
 5000 cycles 28 VDC, 400 Hz Resistive
 2500 cycles 28 VDC, 400 Hz Inductive
 5000 cycles no load

* Other vibration levels available. Contact factory for details.

Approximate Time-Current Curves - 6752-100 Circuit Breakers

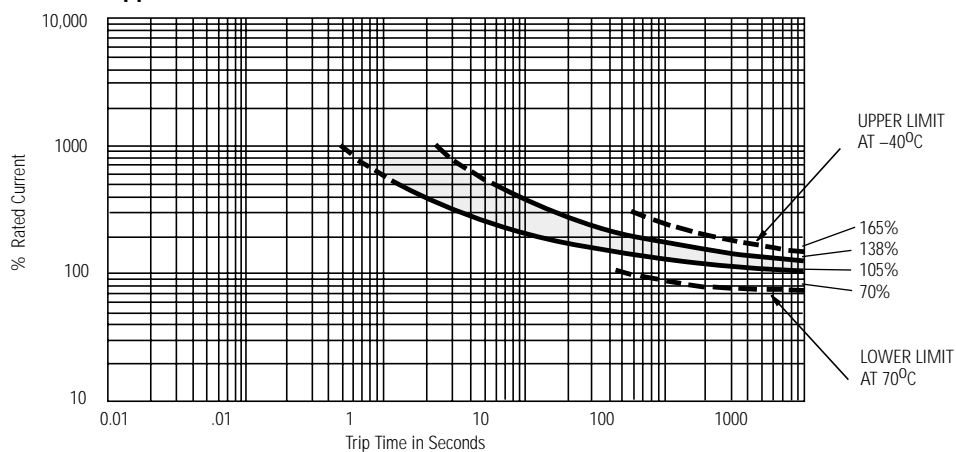



3TC7 Series

Single Phase, Non Ambient Compensated, High Short Circuit Interrupting Capacity

Features

- **Lightweight**
- **Miniature size**
- **High interrupting capacity**
- **High vibration resistance**
- **MIL-C-5809 (MS25244)**
- **Available in 5-35 amperes**



Overview

The Klixon 3TC7 style circuit breaker is a lightweight, high performance, non ambient temperature compensated circuit breaker that is well suited for aircraft, avionics and electrical systems. The 3TC7 series features a trip free design that prevents the circuit breaker from being closed manually on overloads. The 3TC7 interrupting a 6,000A circuit at 30 VDC, or 3,500A circuit at 120 VAC, 400 Hz.

The Klixon trademark continues to set the standard for lightweight configurations and offers the endurance and reliability required by exacting military specifications. The 3TC7 is currently available in 5-35 amperes.

Detailed Performance Data

Interrupting Capacity	6000 Amperes at 30VC	3500 Amperes at 120 VAC, 400 Hz
Endurance	120 VAC, 400 Hz Inductive	2,500 Cycles
	120 VAC, 400 Hz Resistive	5,000 Cycles
	30 VDC, Inductive	2,500 Cycles
	30 VDC, Resistive	5,000 Cycles
	Mechanical, no load	5,000 Cycles
Vibration	10 G's	
Mechanical Shock	30 G's peak	
Acceleration	10 G's	
Weight	39 gm	
Operating Altitude	65,000 ft	

TI Number	MS Number	Amp Rating	Voltage Drop
3TC7-5	MS25244-5	5	.25
3TC7-7½	MS25244-7½	7½	.25
3TC7-10	MS25244-10	10	.25
3TC7-15	MS25244-15	15	.25
3TC7-20	MS25244-20	20	.25
3TC7-25	MS25244-25	25	.25
3TC7-30	MS25244-30	30	.25
3TC7-35	MS25244-35	35	.25

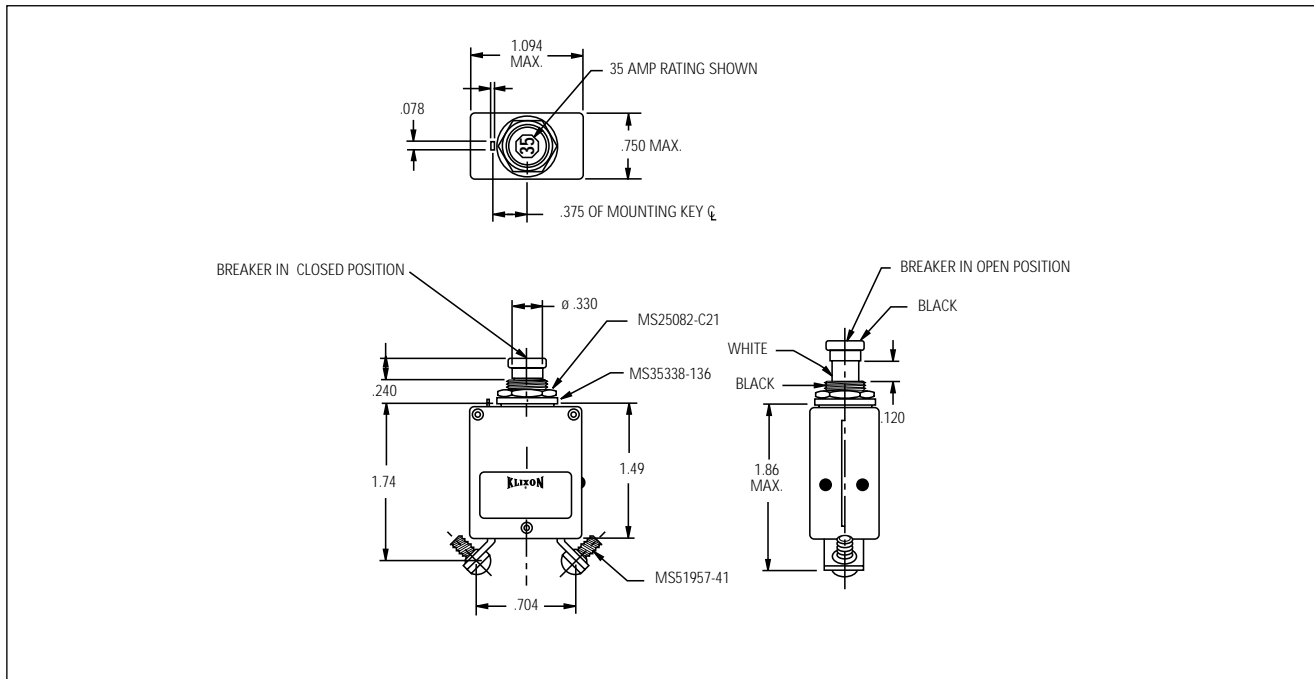

Calibration	Min Ult Trip	Max Ult Trip	200%	400%	600%
+25°C	115%	138%	15 - 55 sec	2.0 - 7.0 sec	1.0 - 3.5 sec
-40°C	148%	178%	-	-	-
+71°C	70%	114%	-	-	-

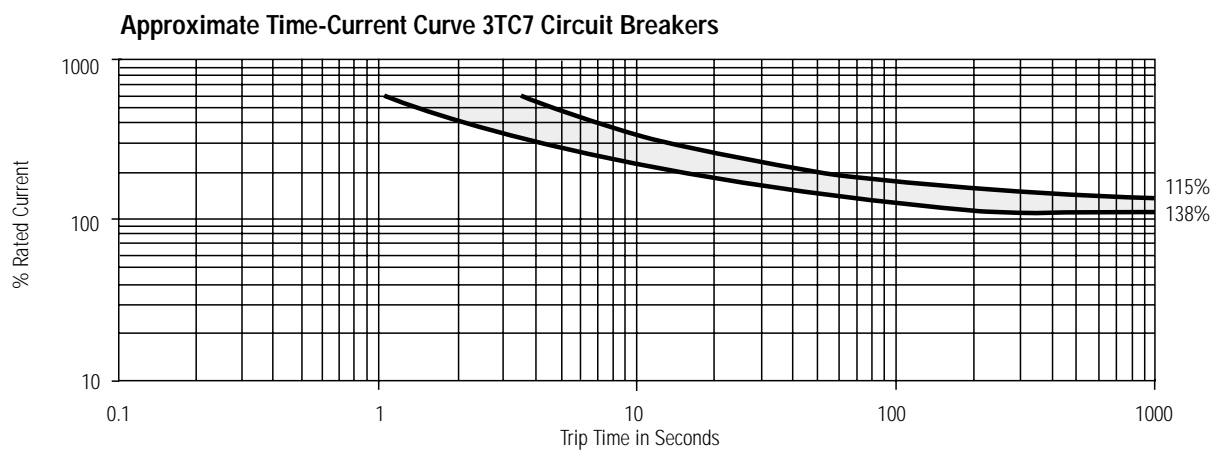



7274 Series Circuit Breakers

Low Amperage, High Performance

Features

- **Uses minimum space**
- **Light weight**
- **Ratings: 1/2 – 20 amperes**
- **Military approved**



7274-2

7274-4

7274-11 and 7274-69

Overview

The 7274 series are small, light weight, low amperage devices that are specifically designed to protect aircraft / aerospace cable such as flat ribbon, fused multi-conductor tape and printed circuit conductors now being used in lighter weight power distribution systems and components in airborne vehicles and equipment.

The 7274 series features a trip-free indicating-type reset button. Also, a “wiping action” contact design assures low voltage drop, faster trip time and high reliability in low voltage applications. They are available in standard ratings from 1/2 – 20 amps.

A water resistant panel seal* designed to fit over the push button actuator is available for applications that require this type of protection.

Options

Long push buttons

Auxiliary switch

Waterproof panel seal

High vibration

TI Number	MS Number	TI Number	MS Number
7274-2-½	MS 26574-½	7274-4-½	MS 26574-½A
7274-2-¾	MS 26574-¾	7274-4-¾	MS 26574-¾A
7274-2-1	MS 26574-1	7274-4-1	MS 26574-1A
7274-2-1½	MS 26574-1½	7274-4-1½	MS 26574-1½A
7274-2-2	MS 26574-2	7274-4-2	MS 26574-2A
7274-2-2½	MS 26574-2½	7274-4-2½	MS 26574-2½A
7274-2-3	MS 26574-3	7274-4-3	MS 26574-3A
7274-2-4	MS 26574-4	7274-4-4	MS 26574-4A
7274-2-5	MS 26574-5	7274-4-5	MS 26574-5A
7274-2-7½	MS 26574-7½	7274-4-7½	MS 26574-7½A
7274-2-10	MS 26574-10	7274-4-10	MS 26574-10A
7274-2-15	N/A	7274-4-15	N/A
7274-2-20	N/A	7274-4-20	N/A
TI Number	MS Number	TI Number	MS Number
7274-11-½	MS 22073-½	7274-69-½	MS 22073-½V
7274-11-¾	MS 22073-¾	7274-69-¾	MS 22073-¾V
7274-11-1	MS 22073-1	7274-69-1	MS 22073-1V
7274-11-1½	MS 22073-1½	7274-69-1½	MS 22073-1½V
7274-11-2	MS 22073-2	7274-69-2	MS 22073-2V
7274-11-2½	MS 22073-2½	7274-69-2½	MS 22073-2½V
7274-11-3	MS 22073-3	7274-69-3	MS 22073-3V
7274-11-4	MS 22073-4	7274-69-4	MS 22073-4V
7274-11-5	MS 22073-5	7274-69-5	MS 22073-5V
7274-11-7½	MS 22073-7½	7274-69-7½	MS 22073-7½V
7274-11-10	MS 22073-10	7274-69-10	MS 22073-10V
7274-11-15	N/A	7274-69-15	N/A
7274-11-20	N/A	7274-69-20	N/A

* Part number 14500-1 fits 7274-11 and other types with 15/32" mounting bushing.
14500-5 fits 7274-2 (7/16").

7274-70 Qualified to MS 26547L for ratings 1/2 amp to 10 amp.

Characteristics

7274

7274-2 and 7274-4

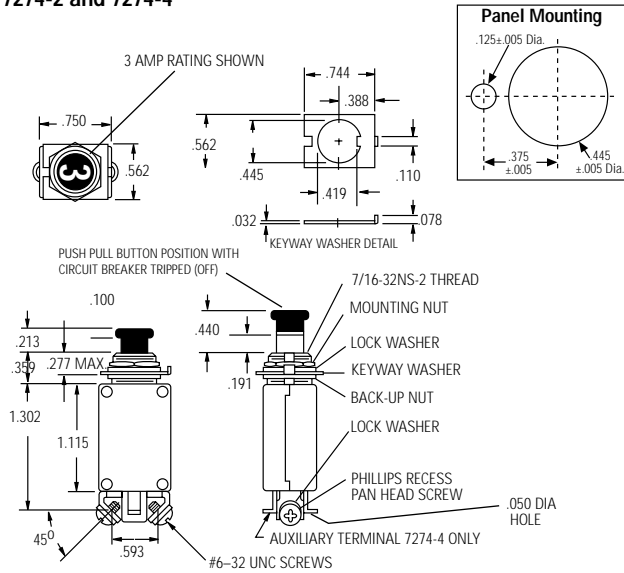

7274-11 and 7274-69

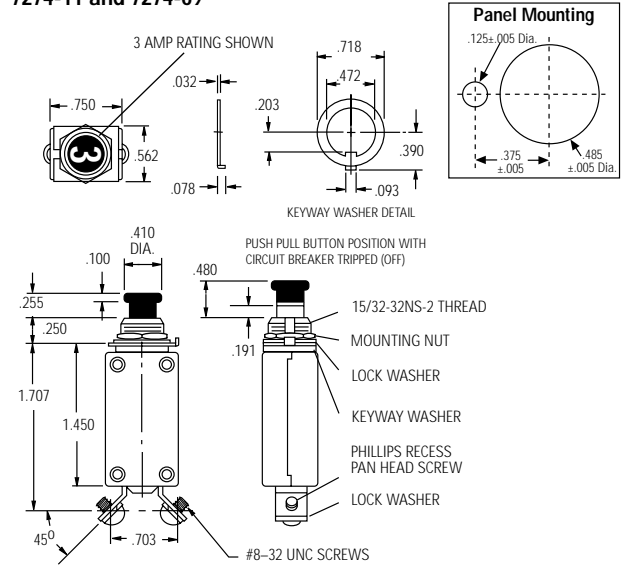

Vibration*	10 G's minimum, 50-500 Hz
Mechanical Shock	35 G's
Acceleration	10 G's minimum
Weight	7274-2: 28 gm max. 7274-4: 28 gm max. 7274-11: 33 gm max. 7274-69: 33 gm max.

Calibration: 1/2-20 amps

Temp °C	Min ULT Trip	Max ULT Trip	Trip Time - Seconds		
			200%	500%	1000%
+25	115%	150%	2-20	.16-1.2	.046-.8
-55	135%	180%	-	-	-
+71	90%	130%	-	-	-

Interrupt Current

1/2 - 5 amps: unlimited at 28 VDC
 7½ - 15 amps: 2000 amps at 28 VDC
 1/2 - 1½ amps: 800 amps at 120 VAC, 400 Hz
 2 - 5 amps: 800 amps at 120 VAC, 400 Hz
 7½ - 20 amps: 500 amps at 120 VAC, 400 Hz

Endurance

2500 cycles	120 VAC, 400 Hz Inductive
5000 cycles	120 VAC, 400 Hz Resistive
2500 cycles	30 VDC, Inductive
5000 cycles	30 VDC, Resistive
5000 cycles	Mechanical, no load

* Other vibration levels available. Contact factory for details.

TI Number	Voltage Drop (Max.)**
7274-XX-½	2.00
7274-XX-¾	1.45
7274-XX-1	1.10
7274-XX-1½	0.75
7274-XX-2	0.75
7274-XX-2½	0.70
7274-XX-3	0.55
7274-XX-4	0.45
7274-XX-5	0.35
7274-XX-7½	0.30
7274-XX-10	0.28
7274-XX-15	0.25
7274-XX-20	0.25

**Max voltage drop at nominal rated current.

Approximate Time-Current Curves 7274 Circuit Breakers

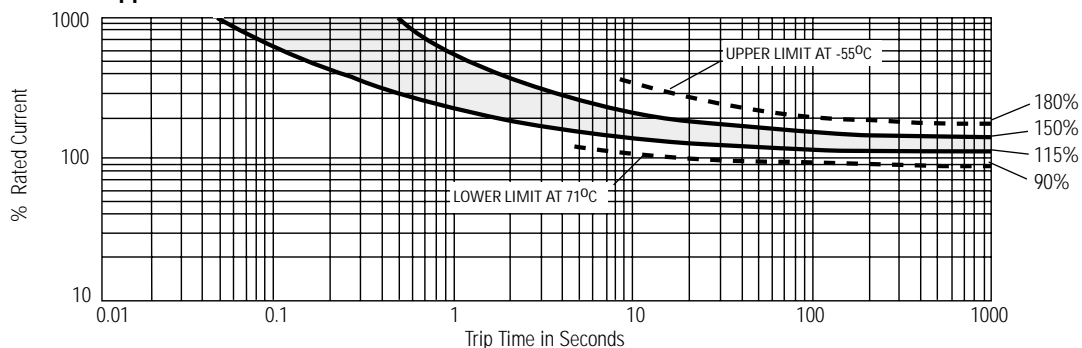



7277 Series Circuit Breakers

Low Amperage, General Application

Features

The 7277 series is designed for applications that do not require the tighter performance characteristics and approvals of our military circuit breakers.

- **Small size**
- **Light weight**
- **Inexpensive**
- **Auxiliary switch**
- **Longer push buttons**



Overview

The 7277 series circuit breaker is physically and electrically identical to the 7274-2 style circuit breaker, with the exception that the 7277 series has wider calibration limits.

Originally developed as an alternative to slow blow fuses, the trip free 7277 is used extensively as primary electrical circuit protection on general aviation aircraft.

The wider calibration limits of the 7277 has also resulted in applications including protection for data processing and telecommunications equipment, computers, flight simulators, construction, material handling and other industrial, electronic equipment.

For use on trainer / simulator applications where all breakers are operated on low ampere control current, different ampere rating inserts (amp ratings on top of push button) can be ordered. Use TI part number 27515.

(Refer to 7274-2 and 7274-4 dimensions on previous page.)

Code System

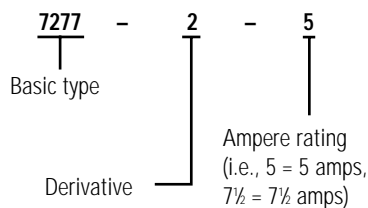

7277-1: Aux. switch version
7277-2: Std. version

Ordering Information

Part Number	Ampere Rating	Max. Drop** (volts)
7277-2-½	1/2	2.00
7277-2-¾	3/4	1.45
7277-2-1	1	1.10
7277-2-1½	1½	0.75
7277-2-2	2	0.70
7277-2-2½	2½	0.50
7277-2-3	3	0.33
7277-2-4	4	0.30
7277-2-5	5	0.25
7277-2-7½	7½	0.20
7277-2-10	10	0.15
7277-2-15	15	0.15
7277-2-20	20	0.15

**Max voltage drop at nominal rated current.

Calibration: 1/2–20 amps*

Temp °C	Min ULT Trip	Max ULT Trip	Trip Time - Seconds		
			200%	500%	1000%
+25	110%	150%	2-35	.15-1.70	.028-.55

* Performance characteristics and dimensions are equivalent to 7274 which are found on page 19.

Approximate Time-Current Curves 7277 Circuit Breakers

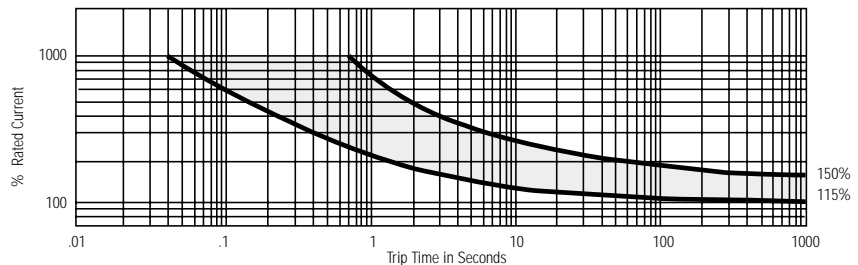

KLIXON[®]

20TC Series Circuit Breakers

Rocker Actuated Switch Type

Features

- **Versatile rocker actuator – snap-on, switch type in various styles and colors for panel mounting**
- **Provides dual function – “ON/OFF” circuit switching and protection**



20TC2

Overview

The Klixon 20TC series circuit breaker offers the advantages of integrating an on/off switch and a circuit protector in a trim, compact package. The snap-on actuators are available on request in a variety of colors, styles and indication markings. They are designed to provide a stylish console appearance to the panels of light aircraft, pleasure boats,

home appliances, office reproducing and calculating machines, and data processing equipment.

Several different types of actuators are available. The translucent actuator permits quick identification of the actuator position under low ambient lighting conditions by emitting a soft glow from a light source, such as an edge lighted panel. Colored

actuators will be hot letter stamped in white. White and translucent actuators will be stamped in black.

The growing demand for a highly stylized and aesthetic panel appearance has generated the need for the 20TC. The basic mechanism has been proven for reliability in a wide variety of applications.

Envelope Drawings

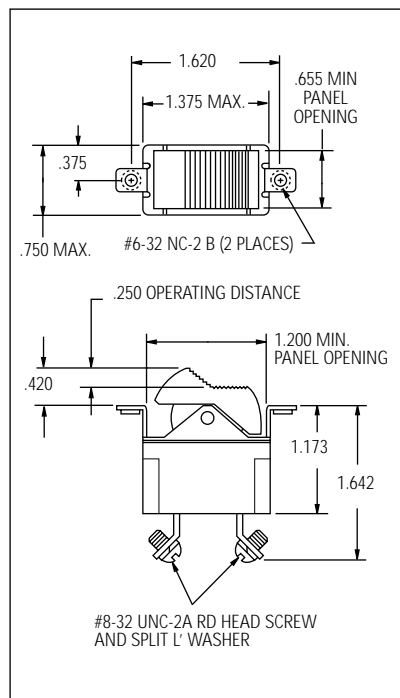

Rocker Button Options (SR12507-156-X)

- 1 PUSH ON / LNDG LITE
- 2 PUSH ON / NAV LITE
- 3 PUSH ON / ANTI COLL
- 4 PUSH ON / PITOT HEAT
- 5 PUSH ON / BOOST PUMP
- 6 PUSH ON / GLIDE SLOPE
- 7 PUSH ON MKR BCN
- 8 PUSH ON / STROBE LITE
- 9 OFF
- 10 OFF
- 11 “SR TO INVERT MARKING”
- 13 PUSH ON / ROT BCN
- 16 PUSH ON / ELEV TRIM
- 18 PUSH ON / RADIO MASTER
- 19 PUSH ON / LDG LITE
- 20 ON / OFF
- 21 OFF
- 22 “COLORED BOX”
- 23 OFF
- 25 ON / OFF
- 26 OFF / ON
- 27 PUSH ON / LOW BOOST
- 28 PUSH ON / HIGH BOOST
- 29 PUSH ON / WX RADAR
- 30 PUSH ON / PROP DE ICE
- 33 PUSH ON / STBY VAC
- 34 NO ACTUATOR
- 35 ON / OFF

Code System

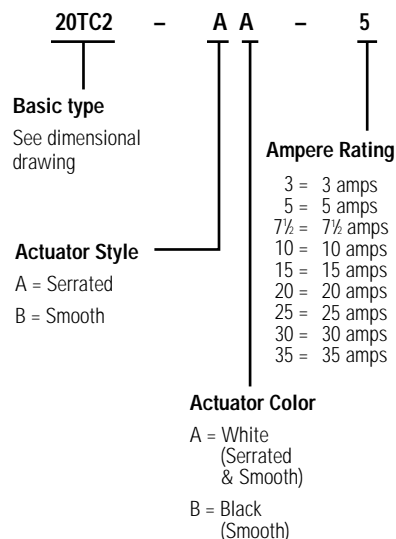

Note: Performance Characteristics similar to 7270/7271 devices on page 22 and 23.



7270 & 7271 Series Circuit Breakers

Miniature Aircraft

Features

- Trip free
- Snap-acting thermal element
- Simplicity of design
- High rupture capacity – 3500 amps, 120 VAC, 400 Hz, 4000 amps, 30VDC
- Light weight
- Small size

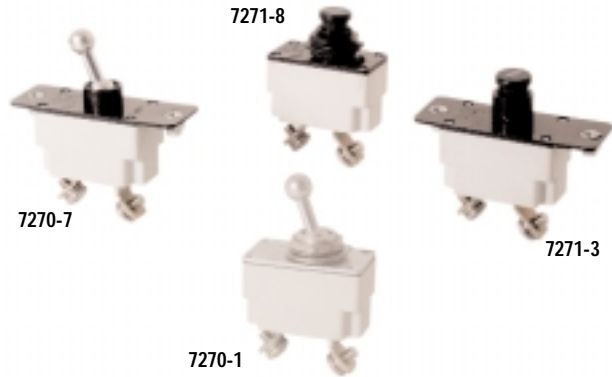

Overview

The Klixon 7270/7271 series circuit breakers were designed to utilize less space behind the panel space while protecting wire and cable in aircraft and ground support equipment on either 120 VAC, 400 Hz or 30 VDC systems. The units are available with neck mounting (7270-1 and 7271-8) or standard cover plate (7270-7 and 7271-3). In each of these Klixon circuit breakers, the bi-metallic element assures uniform current distribution throughout its responsive area. This design reduces current density at the critical areas, resulting in an element having a much higher interrupting capability than conventional design. Inherently resistant to shock and vibration, the Klixon disc element is capable of precise calibration settings and will retain the initial calibration within close tolerances throughout the service life of the breaker. Both circuit breakers have conventional actuator action; i.e., the toggle actuator on the 7270 moves to the OFF position for trip indication and the button of the 7271 pops out. A standard black button with a white collar is used.

Qualifications

TI Number	MS Number	TI Number	MS Number	TI Number	MS Number
7270-1-3	N/A	7270-7-10	MS 24509-B-10	7271-3-25	N/A
7270-1-5	MS 24509-A-5	7270-7-15	MS 24509-B-15	7271-3-30	N/A
7270-1-7½	MS 24509-A-7½	7270-7-20	N/A	7271-3-35	N/A
7270-1-10	MS 24509-A-10	7270-7-25	N/A	7271-8-3	N/A
7270-1-15	MS 24509-A-15	7270-7-30	N/A	7271-8-5	MS 24510-A-5
7270-1-20	N/A	7270-7-35	N/A	7271-8-7½	MS 24510-A-7½
7270-1-25	N/A	7271-3-3	N/A	7271-8-10	MS 24510 A-10
7270-1-30	N/A	7271-3-5	MS 24510-B-5	7271-8-15	MS 24510-A-15
7270-1-35	N/A	7271-3-7½	MS 24510-B-7½	7271-8-20	N/A
7270-7-3	N/A	7271-3-10	MS 24510-B-10	7271-8-25	N/A
7270-7-5	MS 24509-B-5	7271-3-15	MS 24510-B-15	7271-8-30	N/A
7270-7-7½	MS 24509-B-7½	7271-3-20	N/A	7271-8-35	N/A

Optional Covers

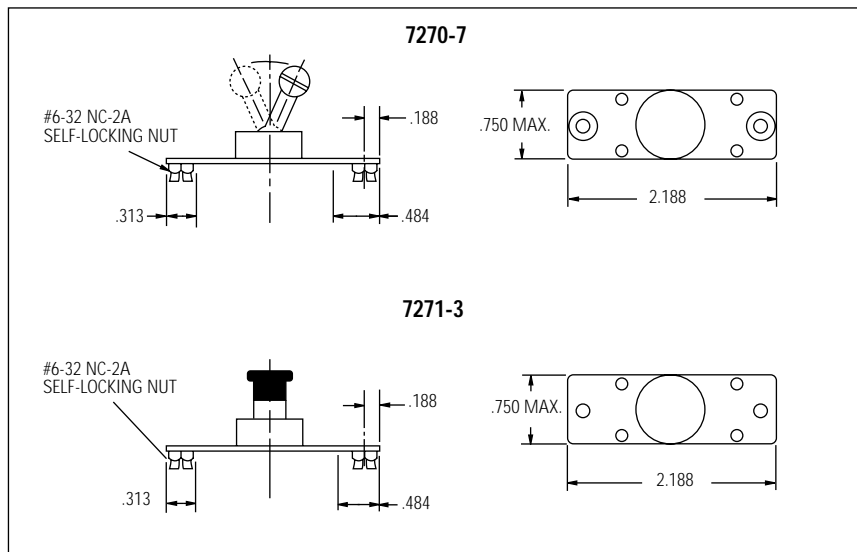

Characteristics

7270/7271

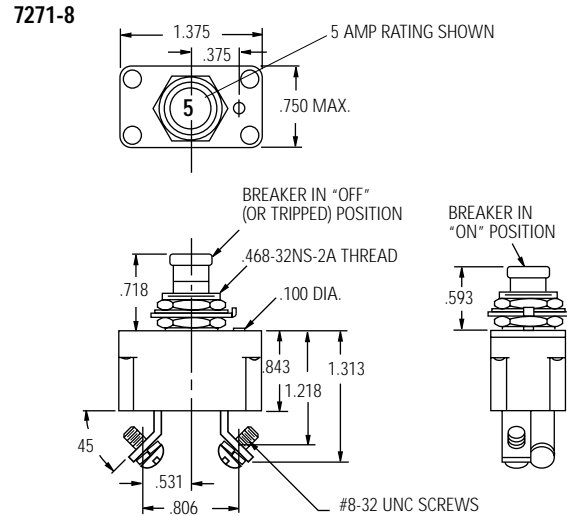
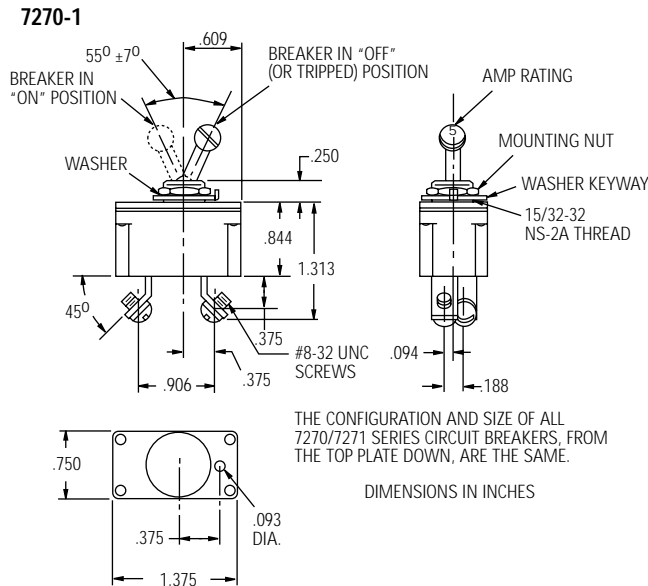

Calibration: 3-35 amps

Temp °C	Min ULT Trip	Max ULT Trip	Rating	Trip Time - Seconds		
				200%	400%	600%
+25	115%	145%	3 amps	40-120	3-26	1-12
			5 amps	40-100	3-22	1-10
			71/2-35	10-70	.75-7.0	.25-2.5
-40	138%	175%	-	-	-	-
+71	80%	125%	-	-	-	-

Vibration* 10 G's minimum, 50-500 Hz
 Mechanical Shock 30 G's
 Acceleration 10 G's
 Weight 7270-1 - 39 gm max.
 7271-8 - 39 gm max.

Interrupt Current

4000 amps, 30 VDC
 3500 amps, 120 VAC, 400 Hz

Endurance

200 cycles 30 VDC Inductive
 5000 cycles 120 VAC, 400 Hz Inductive
 5000 cycles 120 VAC, 400 Hz Resistive
 5000 cycles 30 VAC, 400 Hz Resistive
 10,000 cycles Mechanical, no load

TI Number 7270's	TI Number 7271's	Voltage Drop (Max.)**
7270-x-3	7270-x-3	0.75
7270-x-5	7270-x-5	0.65
7270-x-7½	7270-x-7½	0.5
7270-x-10	7270-x-10	0.5
7270-x-15	7270-x-15	0.5
7270-x-20	7270-x-20	0.5
7270-x-25	7270-x-25	0.5
7270-x-30	7270-x-30	0.5
7270-x-35	7270-x-35	0.5

**Max voltage drop at nominal rated current.

* Other vibration levels available. Contact factory for details.

Approximate Time-Current Curves 7270 and 7271 Circuit Breakers

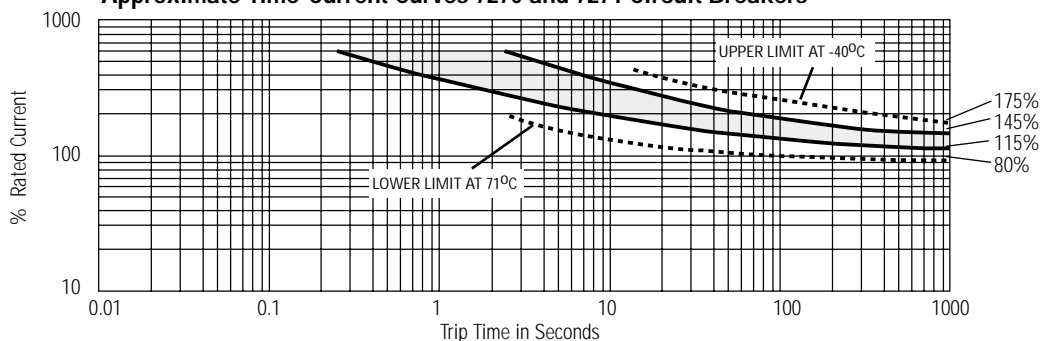



3SB Series Simulator Circuit Breakers

Features

- **Low amperage / fast trip response**
- **High performance**
- **Packaged in Military Standard configuration**
- **Tactile feel equivalent to industry accepted aircraft circuit breakers**
- **Lower total system cost**



Overview

The 3SB Series Simulator Circuit Breaker has been developed by the Precision Products Group of Texas Instruments to meet the growing needs of the commercial and military simulator industry. With more and more training now being conducted on simulators due to the high operational costs of live training, the realism and complexity of tomorrow's simulators will require a circuit breaker that can provide the same "look and feel" of industry accepted circuit breakers, creating a superior training environment.

3SB electromechanical devices provide fast trip response with low current draw at 28 VDC, and are packaged in a standard

MS26574 style thermal circuit breaker configuration for adaptability to aircraft cockpit panel mounting. This fast trip/low current performance provides the opportunity for system level savings by enabling the designer to potentially down size the system power source. This eliminates expensive I/O boards or other electronics while also reducing the amount of cabling required.

Changes in training schemes normally entail system rewiring to reconfigure the simulator, which becomes labor intensive and costly. With the incorporation of the 3SB device, training changes can easily be achieved through system

software, without the time and cost associated with rewiring. TI's simulator circuit breakers also provide the same tactile feel as standard MIL qualified breakers to achieve superior training realism.

Klixon circuit breakers offer the flexibility of ordering replaceable ampere rating inserts. They are attached to the top of the push button actuator, to match the current rating used in the actual aircraft. These inserts can be rotated within the push button to meet your cockpit configuration needs. An optional auxiliary switch for remote indications, along with a variety of connection alternatives, are also available.

Characteristics

3SB

3SB2

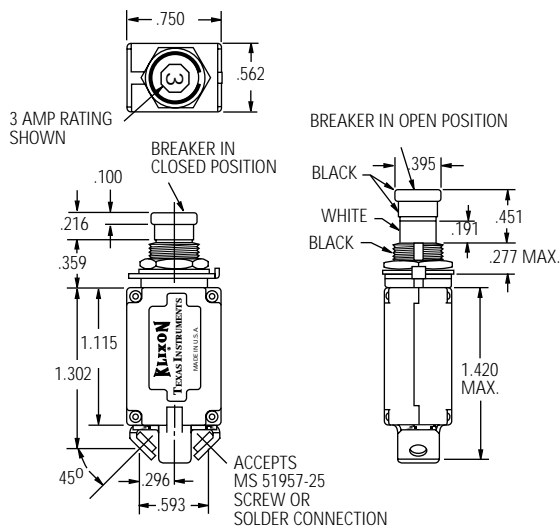

3SB4

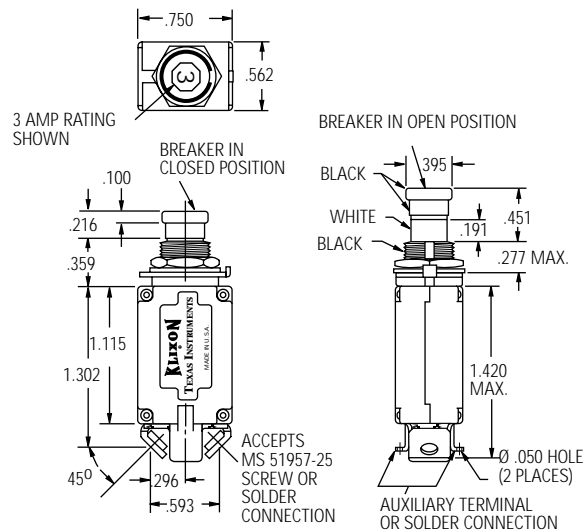

Open and Reset Force ...	5 lbs. max.
Calibration @ 25°C	200 mA max. current draw @ 28 VDC, 3 sec. max trip time
Endurance	5000 mechanical cycles, no load 1000 electrical trip cycles, minimum at 28 VDC
Vibration.....	5 G's maximum 50-500 Hz
Shock	5 G's maximum
Acceleration	5 G's maximum
Weight	30 grams maximum

Dummy Circuit Breakers

Texas Instruments has developed a derivative of our 7274 style circuit breaker expressly for applications in simulators, trainers and cockpit mock-ups.

7274-63D: Dummy breaker. Non-functional 7274-2 style

7274-64PS: Physical sample. 7274-2 style with operational push button. Can measure continuity across terminals.

7274-65PS: Physical sample. 7274-11 style with operational push button. Can measure continuity across terminals.

Part Numbering Code

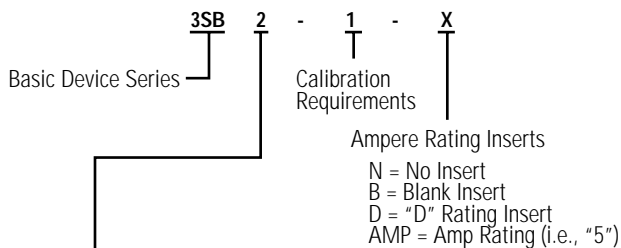

Physical Characteristics

- 2 = Standard device
- 4 = Auxiliary switch
- 21 = Standard device w/cover
- 22 = Standard device w/green push button
- 24 = Auxiliary switch w/green push button
- 41 = Auxiliary switch w/cover



APD Series Circuit Breakers

Arc Fault Protection Device

Features

- **Small and lightweight**
 - **Current ratings 1-25 amperes**
 - **Detects arcs over considerable distances**
 - **Senses small arc currents in presence of large current loads**
 - **Insensitive to RFI/EMI and cross talk signals**
 - **Differentiates between normal load current and arc current**
 - **Immune to load start up transients**
 - **Retrofittable – fits into existing panel designs**
-



Overview

The Arc Fault Circuit Breaker series has been developed by Texas Instruments to meet the evolving needs of the aerospace industry. Traditional circuit breakers were only designed to detect over-current (I^2t) conditions. However, many serious electrical incidents are caused by low level arc fault conditions resulting from damaged or aging wire which present generation circuit breakers are not designed to detect or protect against.

TI recognizes the evolving requirements of the aerospace industry and the need for supplemental arc fault protection. TI developed a small, lightweight package configuration based around proven Klixon® commercial and mil-spec circuit breaker designs, integrating the traditional over-current trip features of today's circuit breakers with new supplemental arc fault detection and protection features. shut down for motor, fan, strobe light, or fluorescent light.

The two arc fault catalog pages represent the first generation of

arc fault circuit breakers that will be used in the commercial aerospace market. The first generation design is based upon the industry need to support 120VAC, 400 Hz aircraft applications.

Future design considerations for the arc fault circuit breakers under development by TI comprehend and include:

- Arc fault trip indication
- 28VDC
- Operating temperature range expansion
- Single phase 30–100A
- Three-phase development
- Ground fault detection
- Variable voltage and frequency options

Ambient Temperature Compensation

The arc fault series of circuit breakers are based on the design of our existing ambient compensated circuit breakers product family permitting system designers to specify smaller gauge wire where the circuit breaker and wiring are exposed to different ambient temperatures. The arc fault

circuit breakers can operate over a temperature range of -54°C to 71°C however, care should be taken to understand the specification limits at elevated ambient temperatures.

Trip Free

The complete line of arc fault series circuit breakers is trip free. The circuit breaker cannot be maintained closed during an overload, even when the actuator is held closed.

High Short Circuit Capacity

The arc fault series of circuit breakers offers unusually high short circuit current interrupting capacity. Depending on the device, overloads of up to 3500 amps at 120VAC, 400 Hz can be safely interrupted.

Options

- Longer push buttons
- High vibration
- Random vibration capability
- U.S. terminals (offset/inline)
- Metric mounting threads

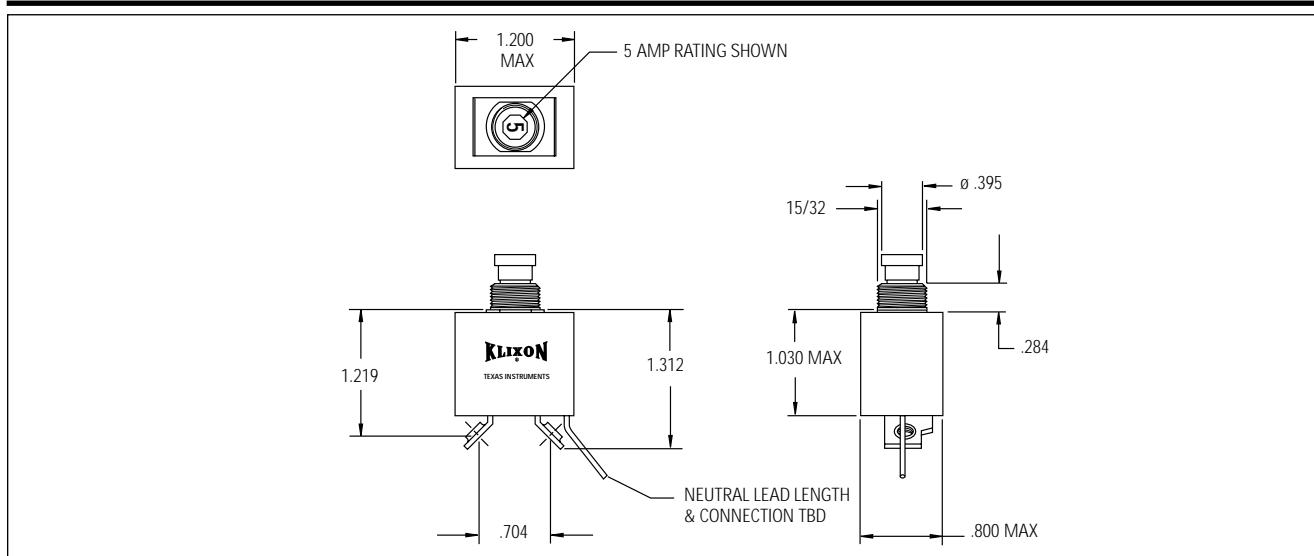

Calibration: 1-25 amps

TEMP °C	MIN ULT TRIP	MAX ULT TRIP	TRIP TIME - SECONDS		
			200%	500%	1000%
+25	115%	138%	4-16	.4-1.6	.10-.40
-54	115%	165%	7-35	.6-3.0	.15-.70
+121	85%	145%	2-13	.25-1.0	.06-.25

Vibration*..... 10 G's minimum, 50 - 500 Hz
 Mechanical Shock..... 50 G's
 Acceleration..... 10 G's
 Weight..... 42 gm max

Interrupt Current

1-20 amps: 6000 amps at 28 VDC
 25 amps: 1625 amps at 28 VDC
 1-15 amps: 2500 amps at 120 VAC, 400 Hz
 20 amps: 2000 amps at 120 VAC, 400 Hz
 25 amps: 1800 amps at 120 VAC, 400 Hz

Endurance

2500 cycles 120 VAC, 400 Hz Inductive
 5000 cycles 120 VAC, 400 Hz Resistive
 2500 cycles 30 VDC Inductive
 5000 cycles 30 VDC Resistive
 10,000 cycles Mechanical, no load

* Other vibration levels available. Contact factory for details.

Performance:

Discrimination (resistance to nuisance trips)

Devices manufactured by TI have demonstrated success on start up, bus transfer, and shut down for motor, fan, strobe light, and fluorescent light.

Detail performance per test document 76508
 Phase to Phase and Phase to Ground 400 Hz, 120/205VAC

Guillotine Arc Test:

Guillotine Arc CurrentLess than 700% RC rms
 Steady State LoadNone to rated current
 Maximum Arcing CyclesEight
 Arcing Time DurationLess than 100ms

Loose Terminal Arc Detection

Steady State LoadLess than 40% RC rms
 Tripping Time:Less than 2 minutes
 Vibration SourceEccentric motor vibratory table

Wet Arc Detection

MIL-STD-2223 Method 3005, wire per MIL-W-81381/11

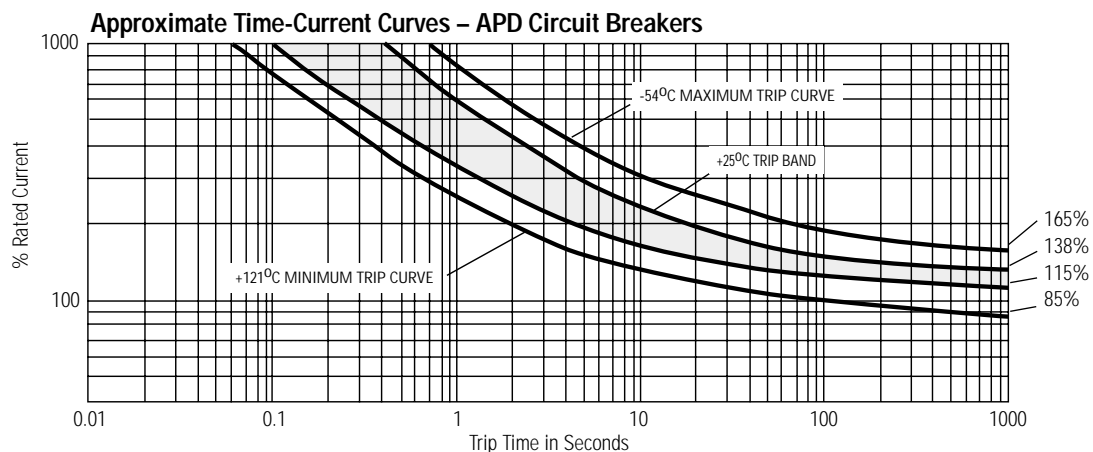



Cross Reference

QPL approved Aircraft Circuit Breakers specifications have been or are in the process of being converted to SAE industry standard. The specification requirements and part marking remains as per the original military slash sheet. The only difference is the SAE industry designation for the military slash sheet.

AS Number	TI Number	AS Number	TI Number	MS Number	TI Number
AS 33201	2TC2	AS 14154V	6TC63	AS 26574A	7274-4
AS 33201L	2TC27	AS 22073	7274-11	AS 26574L	7274-70
AS 33201V	2TC63	AS 22073V	7274-69	AS 24509A	7270-1
AS 14105	3TC2	AS 26574	7274-2	AS 24509B	7270-7
AS 14105L	3TC27			AS 24510A	7271-8
AS 14153	9TC2			AS 24510B	7271-3
AS 14154	6TC2				
AS 14154L	6TC37				

Commercial Aircraft Circuit Breaker Cross Reference

Boeing Basic Specification	TI Style	Airbus Basic Specification	TI Style	Lockheed Basic Specification	TI Style
BACC18U	7274-21	NSA931303	6752-12	LS10158	2TC20, 3TC20
BACC18W	7276-13	NSA931304	6752-305		2TC26/3TC26
BACC18Z	2TC6	NSA931320	2TC50	LS10159S	6TC20, 9TC20
BACC18AA	2TC14	NSA931321	5TC50		6TC26/9TC26
BACC18AC	6TC6	NSA931322	6TC50		
BACC18AD	2TC47	NSA931323	15TC50		
BACC18AE	9TC6	NSA931324	2TC64		
10-60806-XX	6752-304	NSA931325	6TC64		
10-60806-XXXX	6752-311	E0730-005	2TC65		
Boeing (DPD)		E0731-005	6TC65		
5D0001	7274-62	E0732-005	5TC65		
None	7274-55	E0733-005	15TC65		
None	7276-115				

For FAA/PMA part availability go to www.klixon.com

European Norms

EN2495
 EN2592
 EN2794
 EN2995
 EN2996
 EN3661
 EN3662
 EN3773
 EN3774

Simplified Glossary of Circuit Breaker Terms

Circuit breaker – A device designed to carry a specific value of current and automatically open a circuit upon overloads or short circuits.

Thermal circuit breaker – A circuit breaker that senses a current overload based on thermal heating of the sensing element.

Time-current curve – An approximate graph showing the minimum and maximum time a specific breaker will take to trip on various degrees of overload.

Ambient compensation – A feature of some thermal breakers that limits or eliminates thermal derating due to ambient temperature.

Minimum ultimate trip – Current rating at which a breaker will not trip within a certain period (usually 1 hour) at a specified temperature.

Maximum ultimate trip – Current rating at which a breaker must trip within a certain period (usually 1 hour) at a specified temperature.

Thermal derating – Tendency of a breaker to trip at lower current levels due to higher ambient temperatures, and to trip at higher levels due to lower ambient temperatures.

Trip-free – Feature of certain breakers that makes it impossible to hold the breaker closed against an overload.

Manual reset – Method of accomplishing reclosure after circuit interruption has occurred.

Indicating, non-indicating – Whether or not breaker gives prominent visual indication of opening, such as exposing a white band around button, or moving toggle to off position.

Manual trip – Ability of breaker to be opened manually.

Auxiliary circuit – An integrally housed, electrically independent switch linked mechanically to operate with the main circuit breaker contacts.

Voltage drop – The voltage decrease across the breaker due to internal resistance of the device.

WARRANTY

Texas Instruments warrants its circuit breakers against faulty workmanship or the use of defective materials for a period of 18 months from date of manufacture. This warranty applies only to products purchased directly from Texas Instruments or through an authorized Texas Instruments distributor. During the warranty period, any circuit breaker found by Texas Instruments, in its sole judgement, to be defective, will be repaired or replaced, at the option of Texas Instruments. Under no circumstances does Texas Instruments responsibility or liability extend to incidental or consequential damages whatsoever.

The foregoing is in lieu of all warranties express, implied or statutory, including, but not limited to, any implied warranty of merchantability and fitness for a purpose and of any other warranty obligation on the part of Texas Instruments.

Important Notice: Texas Instruments (TI) reserves the right to make changes to or discontinue any product or service identified in this publication without notice. TI advises its customers to obtain the latest version of the relevant information to verify, before placing orders, that the information being relied upon is current. TI assumes no responsibility for infringement of patents or rights of others based on TI applications assistance or product specifications since TI does not possess full access concerning the use or application of customers' products. TI also assumes no responsibility for customers' product designs.