

CM-7 DIMENSIONS

Hawse Pipe Flange
Dimension — 5" X 6-1/2"

SPECIFICATIONS:	
Voltage:	12 / 24 / 32 VDC
Current:	7 - 9 Amps under load
Weight:	21 lbs. (Power Unit) 8 lbs. (Hawse Pipe)
Cable size:	6/3 or 6/4, 50 amp, 220 volt Adjustable (7/8" to 1-1/4" diameter)
Length capacity:	Determined by size of storage location

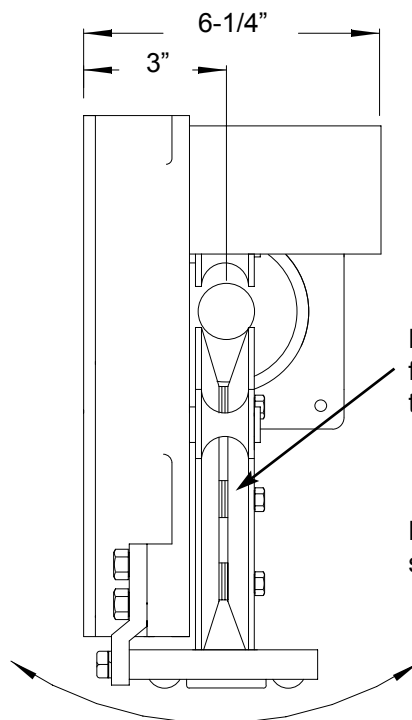
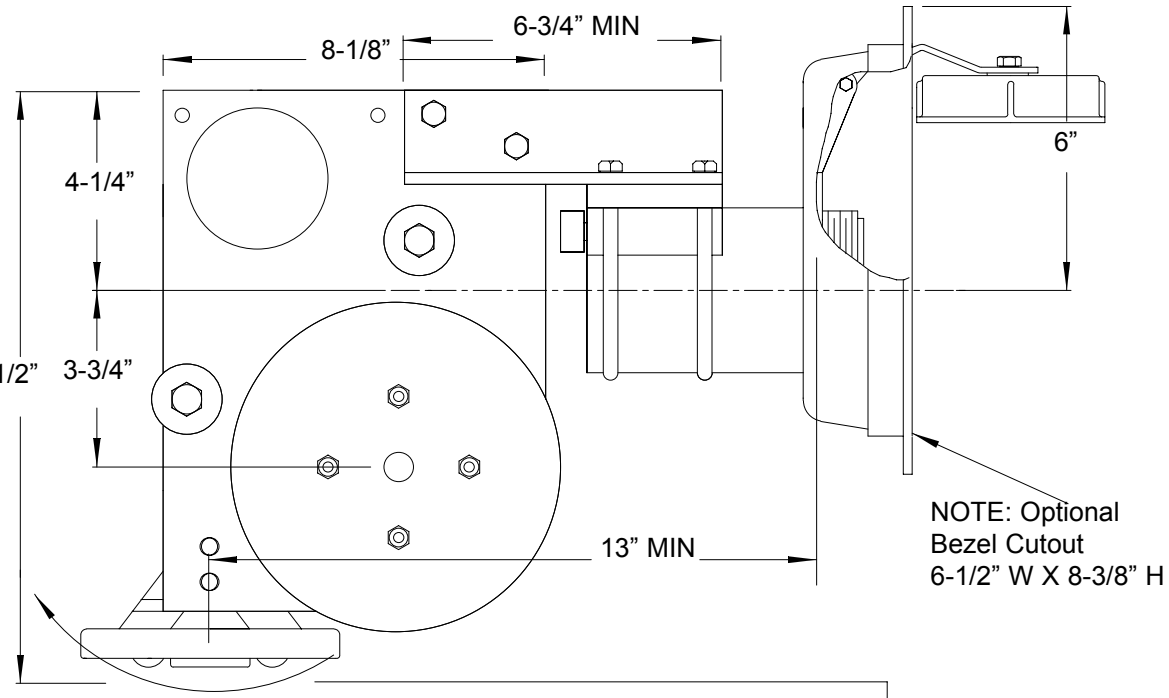
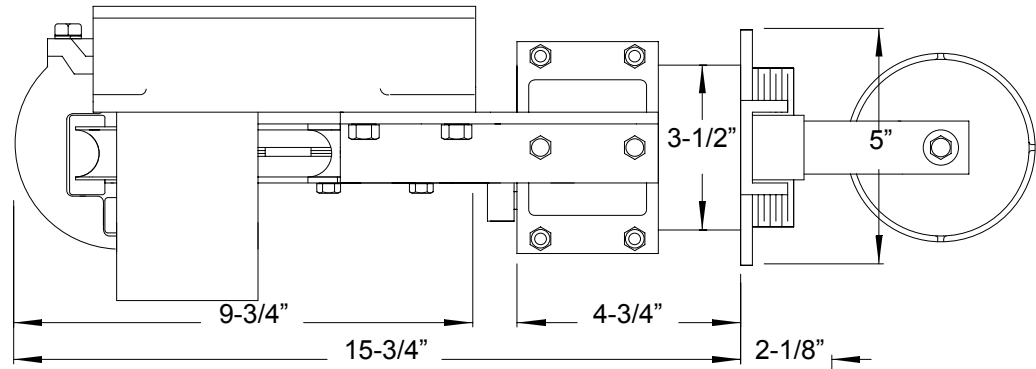

NOTE: Spacers provided for variable cable diameter adjustment

NOTE: Power Unit may swing up to 45 degrees

NOTE: Optional Bezel Cutout 6-1/2" W X 8-3/8" H

Minimum cable area required for 50 feet of 50 amp shore power cable is 18" diameter X 18" high (centered under Guide Roller Assembly)