

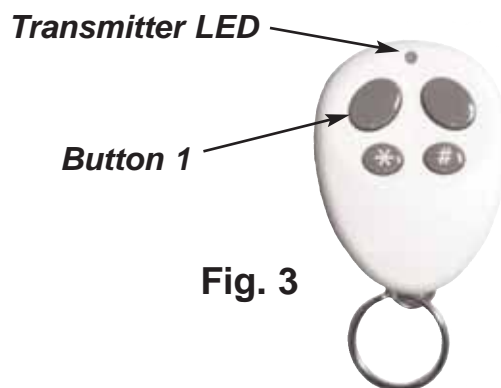

## REMOTE CONTROL PROGRAMMING

Locate the program switch under the access panel on the front of the Remote Control module as shown below (Fig. 1).

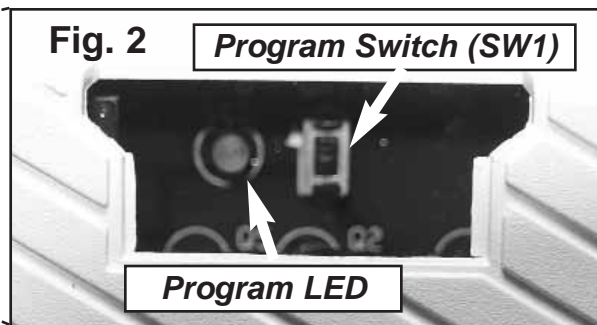
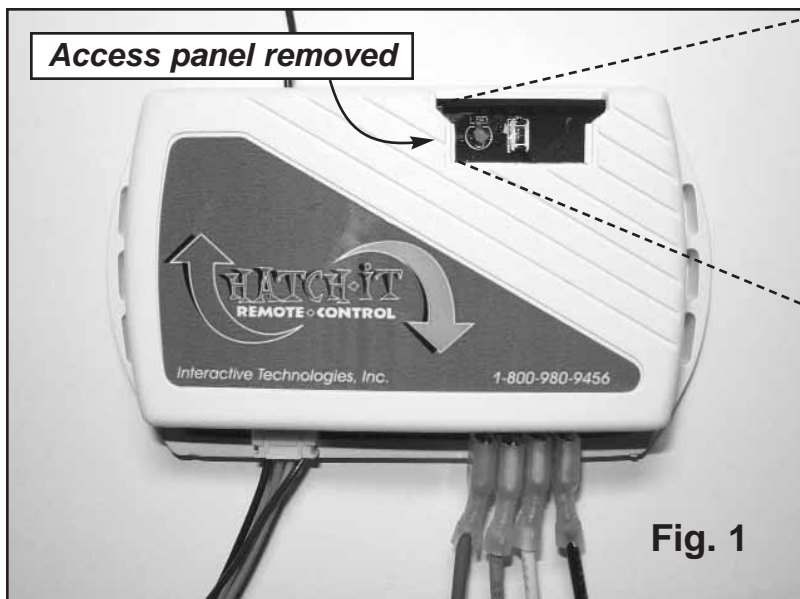

*Read through the steps below BEFORE you begin.  
You will have 10 seconds to complete the programming sequence.*

1. Push the program switch (SW1) (Fig. 2) until the red program LED lights solid, then release switch.
2. Push button 1 on the remote transmitter until the program LED goes out (Fig. 3).
3. Push button 1 on the transmitter again, the program LED should flash slowly ... now release button.
4. Remote is now programmed. Test unit.

NOTE: If the remote does not work, make sure that the transmitter LED is flashing when button 1 is pressed, and that the battery is good. Repeat steps 1-4.

5. Repeat steps 1-4 for second transmitter.

# CABLEMASTER REMOTE CONTROL WIRING DIAG

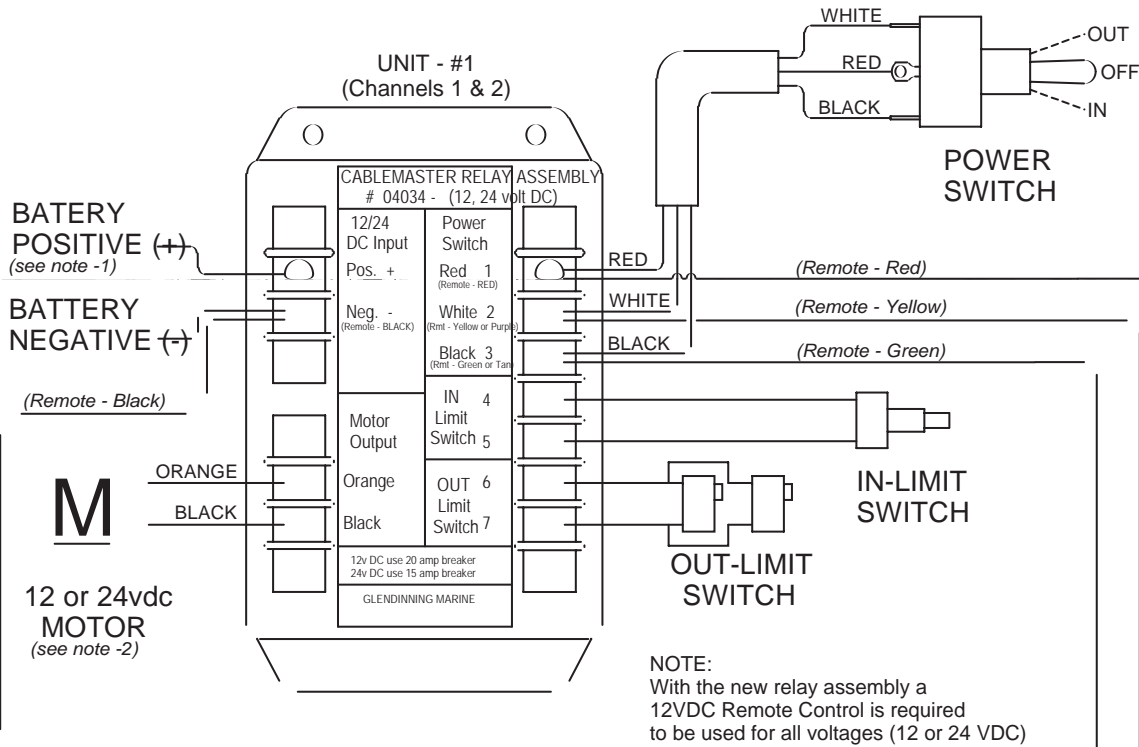

(if operating 2 Cablemasters)

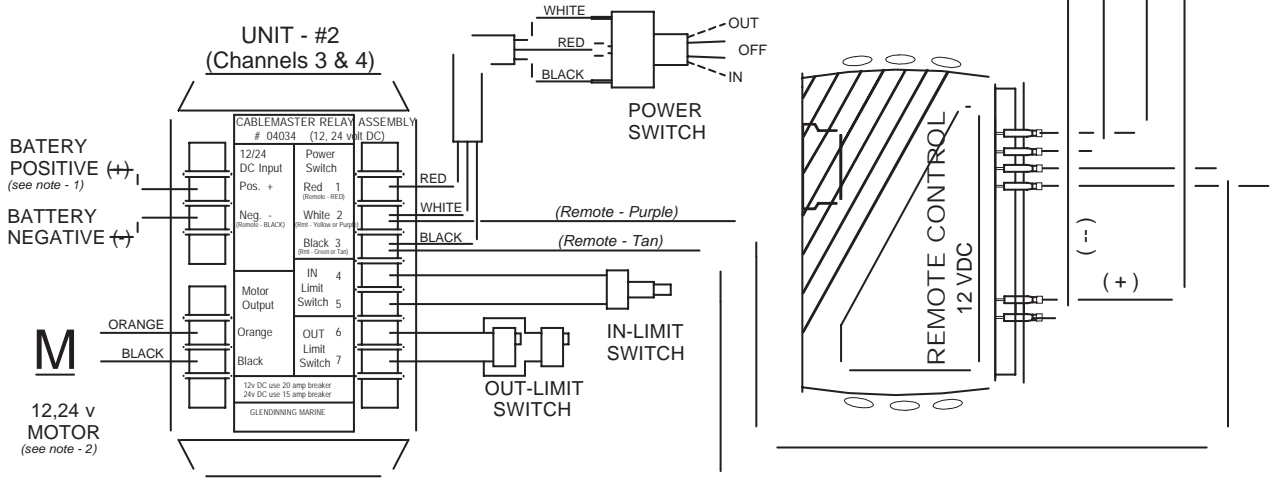

Note:

- 1.) Connect battery positive lead via fuse or circuit breaker. See Installation Manual for rating.

Circuit Breaker Specs.:

CM7 - 12 Volt 20 Amp Breaker 8-10 Running Amps  
CM7 - 24 Volt 15 Amp Breaker 5-6 Running Amps

- 2.) For low profile Cablemaster installation, the motor leads must be reversed for correct limit switch operation. See manual for more information.

