

INSTALLATION APPLICATIONS

There are various ways to install the Cablemaster™ – choosing which method is right for you will depend on the location and the amount of space available. This document illustrates several installation applications which may be used separately or combined to achieve the desired installation specification.

CLOSE-COUPLED APPLICATION

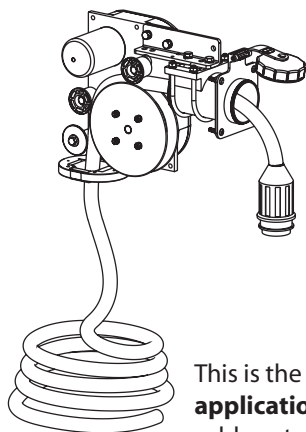

When sufficient storage space is available, this is perhaps the easiest installation method. The Hawse Pipe is “close-coupled” to the Power Unit allowing the power cable to free fall into the storage space directly underneath the Power Unit.

This is the **recommended installation application** and ensures proper cable extension and retraction.

HORIZONTAL EXTENSION APPLICATION

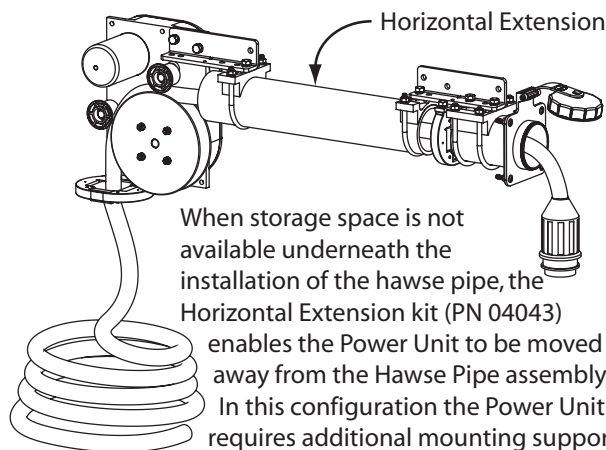

When storage space is not available underneath the installation of the hawse pipe, the Horizontal Extension kit (PN 04043) enables the Power Unit to be moved away from the Hawse Pipe assembly. In this configuration the Power Unit requires additional mounting support.

VERTICAL EXTENSION APPLICATION

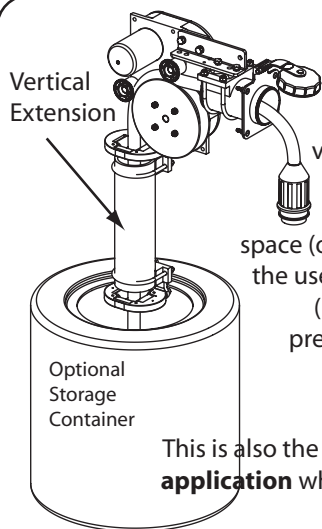

When there is too much vertical distance between the bottom of the Power Unit and the top of the storage space (or container), we recommend the use of the Vertical Extension kit (PN 04044). The use of this kit prevents the cable from spilling out of the storage space.

This is also the **recommended installation application** when the power cable is being directed through the deck.

COIL SPRING APPLICATION

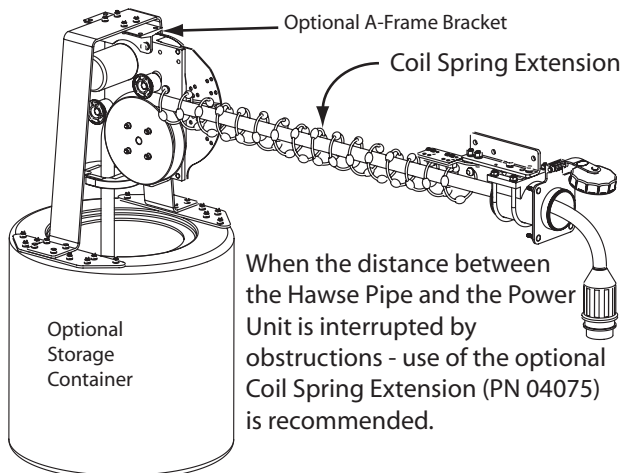

When the distance between the Hawse Pipe and the Power Unit is interrupted by obstructions - use of the optional Coil Spring Extension (PN 04075) is recommended.

STORAGE SPACE OPTIONS

Before installing the Cablemaster™, careful consideration should be given to the storage space where the Cablemaster™ will store your boat's shore power cable. There are three options to choose from, either would perform well.

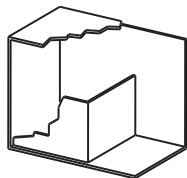

- PRE-FAB WALL**
- build-it-yourself
 - surface must be smooth
 - keeps cable contained



- STYRENE CONTAINER**
- available from GMP:
 - PN 85420 - 20.0" dia. x 18.0" H
 - PN 85421 - 22.0" dia. x 15.0" H
 - PN 85424 - 18.0" dia. x 18.0" H
 - PN 85425 - 22.0" dia. x 22.0" H
 - PN 85427 - 20.0" dia. x 12.0" H



- INSTALLER SUPPLIED**
- heavy-duty garbage barrel
 - round baitwell
 - “rubbermaid” bucket etc.

WHAT YOU WILL NEED FOR A TYPICAL 50 AMP SERVICE — MODEL CM-7

CLOSED COUPLED APPLICATION

PART NO.	DESCRIPTION
04020	Model CM-7 Cablemaster™ (specify 12 or 24VDC) Includes: — Stainless Steel Hawse Pipe Assembly — Power Unit — In-Limit and Out-Limit switches — Nameplate
9400X	<i>Optional</i> — Shore Power Cable (X = cable type and white or yellow outer jacket color)
9940X	<i>Optional</i> — Plug
9941X	<i>Optional</i> — Plug Cover (X = white or yellow color)
8542X	<i>Optional</i> — Cable Storage Containers (X = diameter and height of container)

HORIZONTAL EXTENSION APPLICATION (if needed add to the above Closed Coupled Application)

PART NO.	DESCRIPTION
04043	Horizontal Extension Pipe Assembly Includes: — Pipe Clamp Assemblies — Connecting Link — 3 feet of PVC Tubing (you may shorten the PVC during installation if necessary)
50006	Overhead Mounting Bracket
50407	Power Unit to Container Mounting Bracket - 12 inch
50408	Power Unit to Container Mounting Bracket - 17 inch
04061	PVC Roller Assembly - Straight (used for installations where horizontal extension is longer than 3 feet)
The Horizontal Extension is only for straight cable runs from Hawse Pipe Assembly to the Power Unit. If a bend is required, use Angling Assemblies (see below) in conjunction with Horizontal Extension	

VERTICAL EXTENSION APPLICATION (if needed add to the above Closed Coupled Application)

PART NO.	DESCRIPTION
04044	Vertical Extension Pipe Assembly Includes: — Pipe Clamp Assembly — Pipe Extension Plate — Guide Roller Assembly — 3 feet of PVC Tubing (you may shorten the PVC during installation if necessary)
The Vertical Extension is only for straight cable runs from the Power Unit to the Cable Storage Container.	

ANGLING ASSEMBLIES (if needed add to the above Closed Coupled or Horizontal Extension Application)

PART NO.	DESCRIPTION
0406X	Angling Assemblies (X = 30 degree sections up to 180 degrees)
04075	Coil Spring Extension (available in 18", 36", 60", and 66" lengths / horizontal or vertical)
04045	Pipe to Pipe Angle Assembly

cm_application_guide v1.0



Custom Marine Services ~ Distributor Marine Electrical Products
1548-B Francis Marion Rd
Florence, SC 29506

Ph: 800.992.7922
Fax: 800.992.7923
Web: cmsquick.com