



# Mechanical Drive Adapter Installation

## Adapting the Automatic Synchronizer for use with a Caterpillar 3116 and 3126 Engine

*This kit is used for supplying tach information for the Glendinning Synchronizer and the Glendinning Electronic Engine Controls for mechanical governor engines only.*

### STEP 1: MOUNTING STANDOFF

Locate vacant mounting holes on front of engine block. Install standoffs by screwing two 5-5/8" standoffs into the vacant holes. Tighten standoffs to engine block.

**FRONT VIEW**

Use this hole to mount standoff

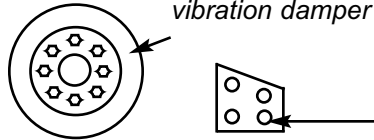

vibration damper

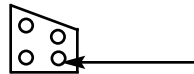

Use this hole to mount standoff

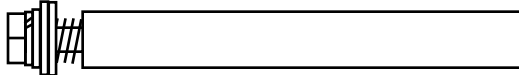

### STEP 2: MOUNTING DRIVE PLATE

Mount Drive Plate onto vibration damper by removing bolts on cover. Reattach bolts to damper by tightening each bolt equally and gradually. DO NOT USE washers that were originally installed with bolt to damper.

**SIDE VIEW**

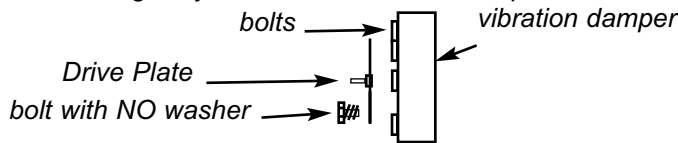

bolts

vibration damper

Drive Plate

bolt with NO washer

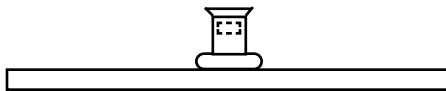

### STEP 3: MOUNTING ADAPTER PLATE

Install triangular adapter plate onto standoffs as shown. LEAVE BOLTS LOOSE at this time.

**FRONT VIEW**

Use holes for correct engine type

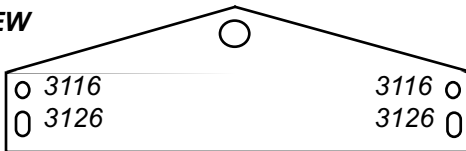

Use holes for correct engine type



### STEP 4: ALIGNMENT

Snap plastic bushing into adapter plate. Insert small end of alignment tool through plastic bushing & insert into the drive plate pin. Move adapter plate so that the alignment tool is centered on the drive plate pin and can be EASILY removed and re-inserted. Hold alignment tool in the centered position while tightening the two adapter plate bolts. Make sure alignment tool can still be EASILY removed and re-inserted into drive plate pin.

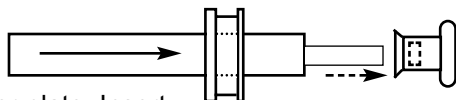

## STEP 5: FLEX SHAFT INSTALLATION



Insert Flex Shaft through Adapter Plate, through Hex Nut and into Drive Plate Pin. NOTE: Grease has been pre-applied to this pin. If you are installing a new pin in a currently installed adapter kit, grease this pin with any general purpose grease.

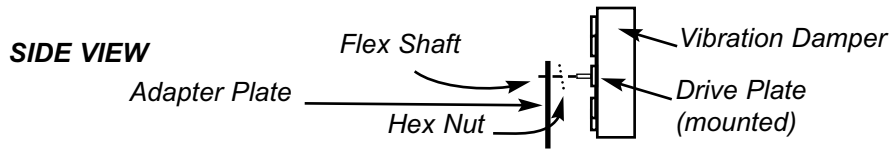

## STEP 6: MOUNTING DRIVE JOINTS

Insert Drive Joint through Adapter Plate; adjust and tighten nut so that there is 1/8" of end play (in and out movement) in Flex Shaft. NOTE: Grease has been pre-applied. Make sure that the correct end of the Drive Joint is installed in the Adapter Plate. Grease fitting must point straight out from the engine (see photo).

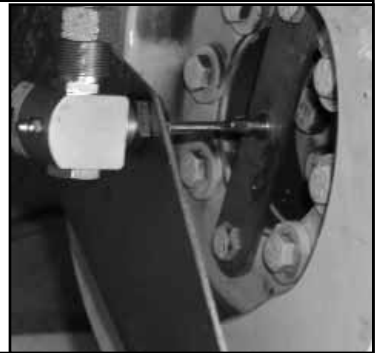
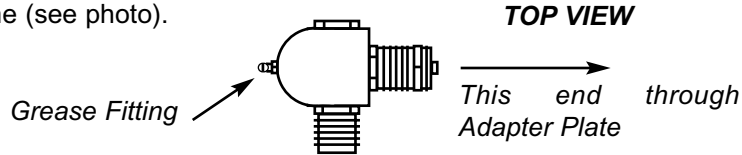

## STEP 7: CONNECTING DRIVE CABLE

Connect Drive Cable to drive joint. Tighten Drive Cable nut. Make sure Drive Cable has a 6-inch straight run before making any bends; also make sure cable is strapped properly.

### NOTE:

Make sure to align notch in Drive Joint with tang on Cable tip

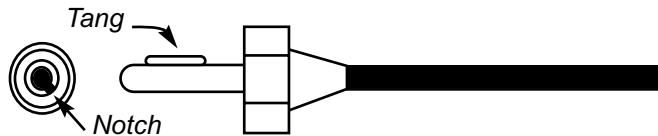

## STEP 8: CHECKOUT

Make sure all connections are tight and everything remains clear from Vibration Damper. Start engine and check to see that Flex Shaft runs true (on center) and does not "wobble" more than 1/32".

### PARTS LIST (New Style)

06001-2.58	Square Flex Shaft
32002	AC10R10 Drive Adapter (.500 Direct Rotation)
51615	Adapter Standoff (x2)
51672	Drive Plate Fitting
60601	CAT 3116 Adapter Plate
60605	CAT 3116 Drive Plate
70452	5/16-18 x 1-1/4 Screw (x4)
72409	5/16 Flat Washer
72604	3/8 Flat Washer
73003	5/16 Lock Washer

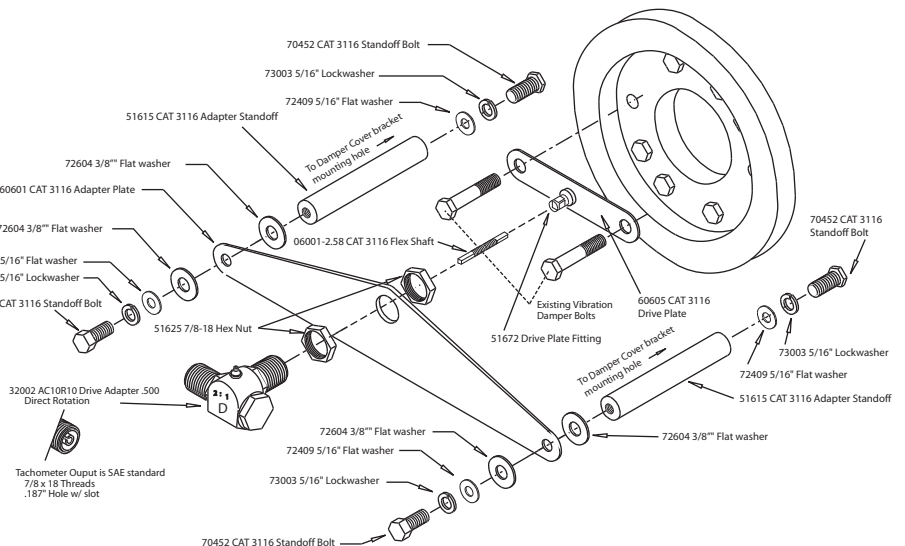

# GLENDINNING

Custom Marine Services  
Florence, SC 29506 USA

800.992.7922  
843.673.2820  
www.cmsquick.com