

## INSTALLATION ON DETROIT DIESEL ENGINES

Based on engine governor PULL to OPEN and engine Take-off outputs CLOCKWISE

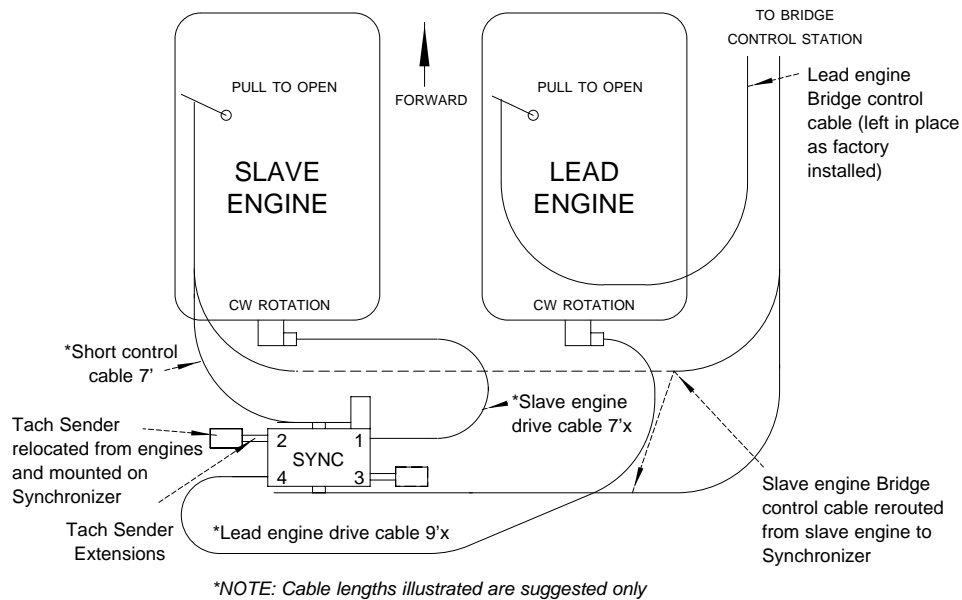

## INSTALLATION ON 3116 CATERPILLAR ENGINES

Based on engine governor PULL to OPEN and Hynautic Hydraulic Controls

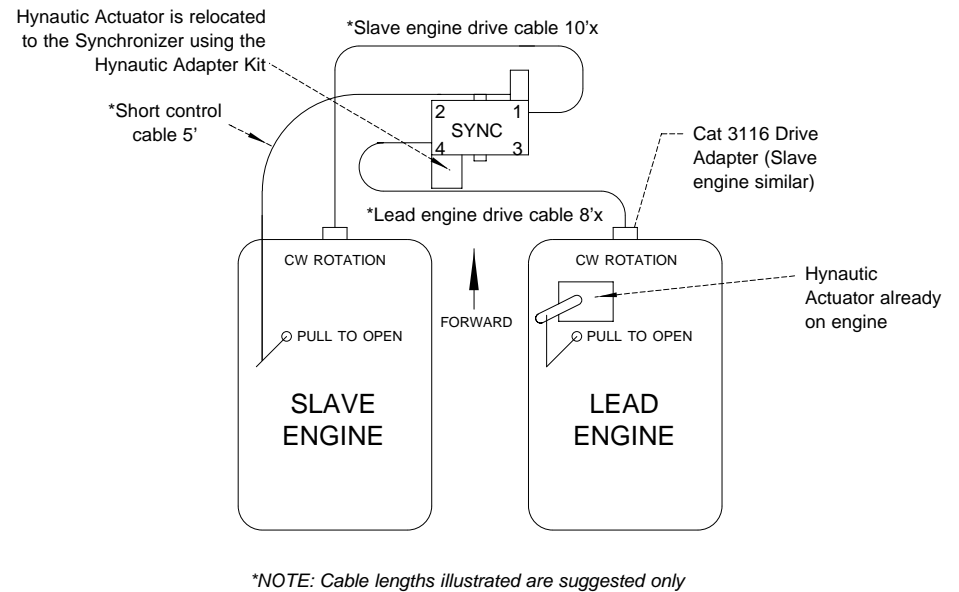

## INSTALLATION ON PURSUIT 300 EXPRESS

NOTE:

- Cummins 4B0250 setup Pull to Open
- Sync mounted on forward bulkhead
- Cable routings based on engine throttle PULL to OPEN and Drive Adapter outputs CLOCKWISE
- Boat has a straight drive transmission

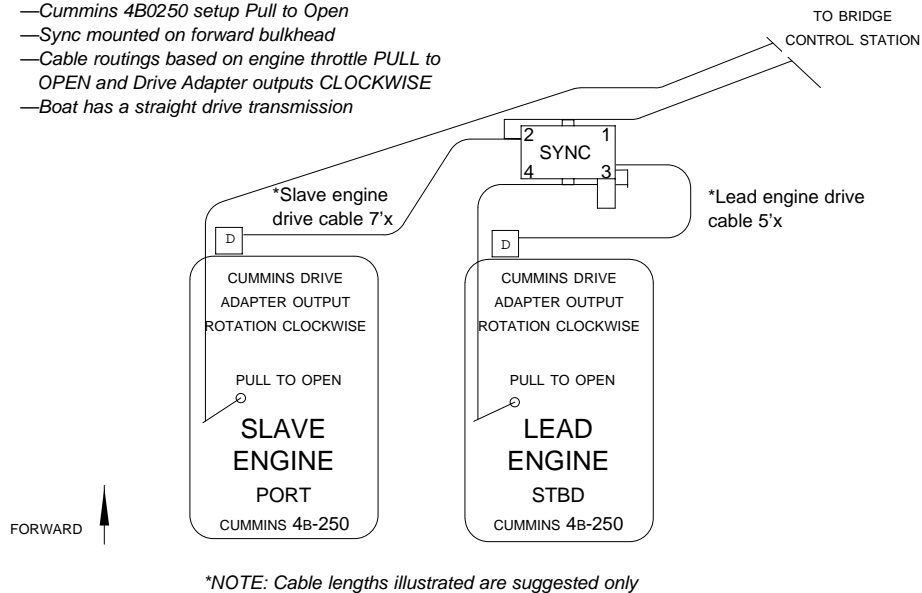

## INSTALLATION ON SEA RAY 400 DA

Based on engine governor PULL to OPEN and Drive Adapter outputs CLOCKWISE and Counter-CLOCKWISE. Boat has a V-drive transmission

